

**MANUEL DE VOL APPROUVE  
et  
GUIDE UTILISATEUR**

**PILOT'S OPERATING HANDBOOK  
and  
APPROVED AIRPLANE FLIGHT MANUAL**

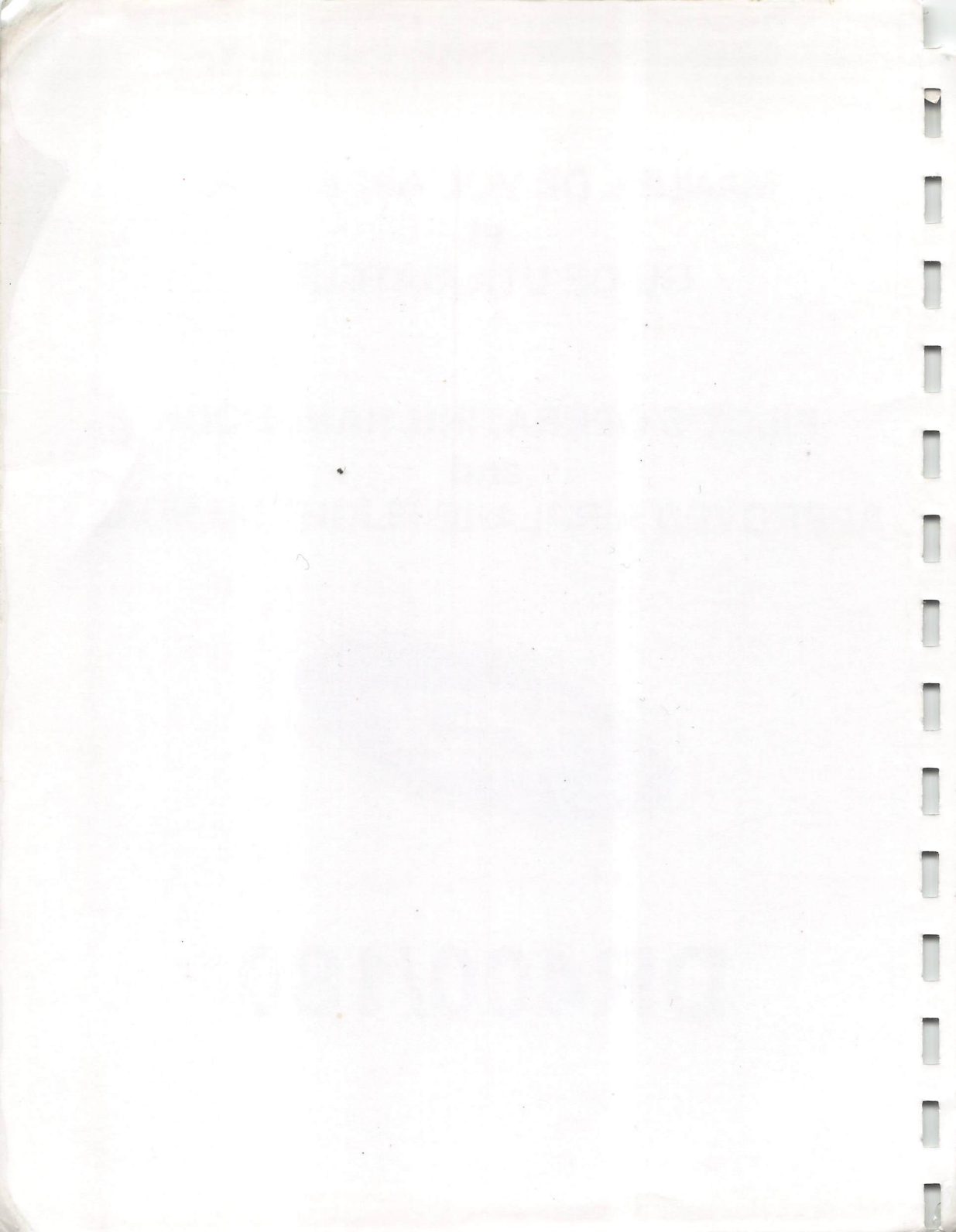

**DR400/180**





Manufacturer: **Apex Aircraft**  
1, route de Troyes  
21121 DAROIS  
FRANCE  
Tél. +33 (0)3 80 35 65 10  
Fax +33 (0)3 80 35 65 15  
www.apex-aircraft.com

Type certificate nr 45, dated 10.05.1972

Serial number 2569

Registration HB-KOE

EASA approval

Approval from the Executive Director  
N° 2005-2530  
dated 23 March 2005

This publication includes the material required to be furnished to the pilot by FAR Part 23 and AIR 2052, and constitutes the EASA approved Airplane Flight Manual.

*Ce manuel est la traduction en langue anglaise du manuel français approuvé.*

This aircraft must be operated within the operating limits specified in this flight manual.

**THIS DOCUMENT MUST BE PERMANENTLY KEPT  
ON BOARD THE AIRCRAFT.**

This edition is applicable from s/n 2216 included.

Document nr 1001587 GB

5268  
HB-KOE

## TABLE OF CONTENTS

General .....	Section 0
Description .....	Section 1
Limitations .....	Section 2
Emergency procedures .....	Section 3
Normal procedures .....	Section 4
Performance .....	Section 5
Weight and balance .....	Section 6
Optional equipment .....	Section 7

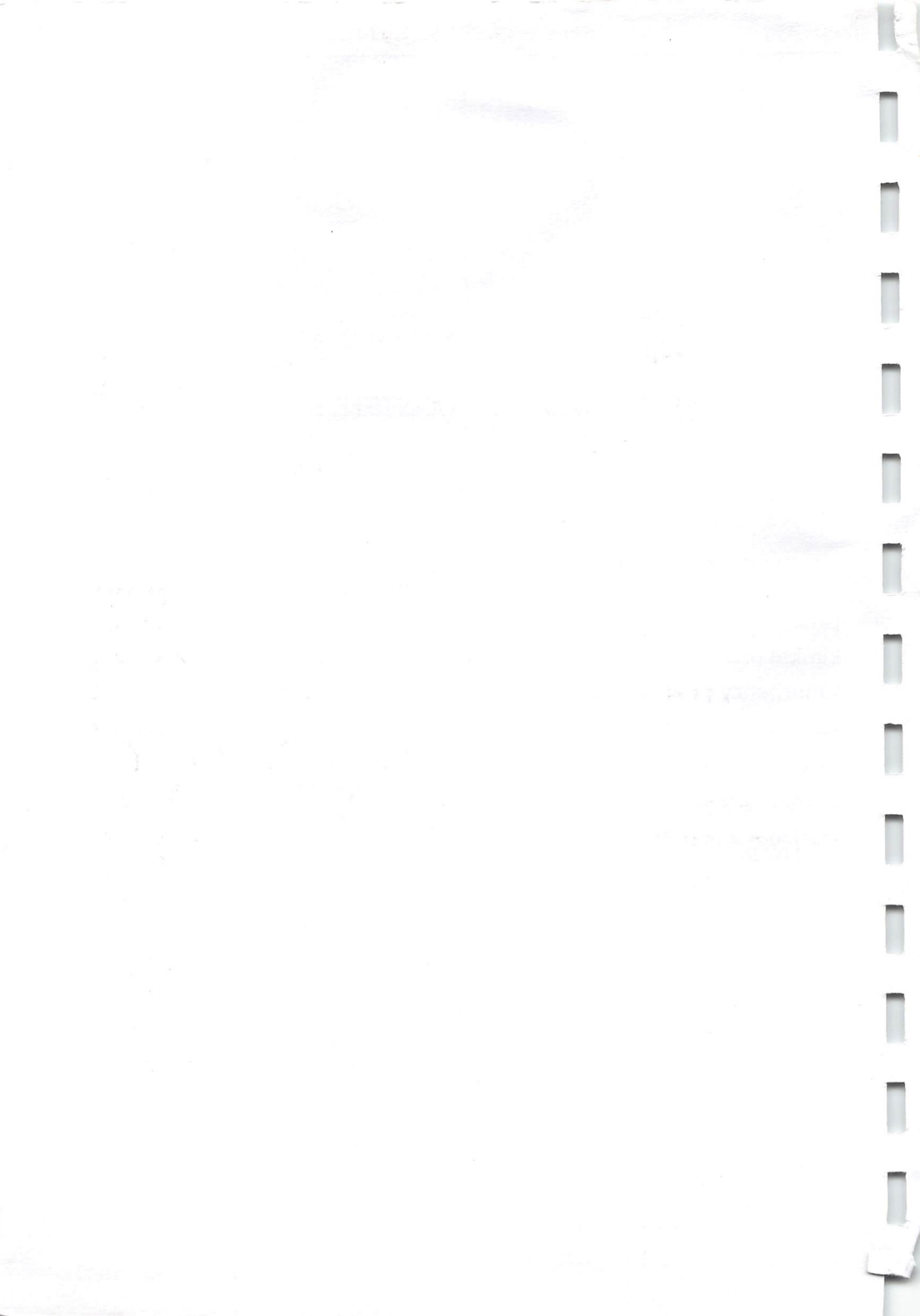



## LIST OF PAGES

First page.....	Edition 12 ....	revision 7 .....	<b>March 2013</b>
i.....	Edition 12 ....	revision 3 - ..	October 1997
ii to iii.....	Edition 12 ....	<b>revision 7 .....</b>	<b>March 2013</b>
iv.....	Edition 12 ....	revision 5 - .....	March 2002
v.....	Edition 12 ....	<b>revision 7 - ...</b>	<b>March 2013</b>
0.01 to 0.02.....	Edition 12 ....	revision 2 - .....	March 1995
0.03.....	Edition 12 ....	revision 4 - .....	June 2001
0.04 to 0.06.....	Edition 12 ....	revision 2 - .....	March 1995
1.01 to 1.02.....	Edition 12 ....	revision 2 - .....	March 1995
1.03 to 1.04.....	Edition 12 .....		May 1990
1.05 to 1.07.....	Edition 12 ....	<b>revision 7 - ....</b>	<b>March 2013</b>
1.08.....	Edition 12 ....	revision 2 - .....	March 1995
1.09.....	Edition 12 ....	revision 4 - .....	June 2001
1.10 to 1.11.....	Edition 12 ....	revision 2 - .....	March 1995
1.12.....	Edition 12 ....	revision 4 - .....	June 2001
2.01.....	Edition 12 ....	revision 2 - .....	March 1995
2.02 to 2.04.....	Edition 12 .....		May 1990
2.05.....	Edition 12 ....	<b>revision 7 - ....</b>	<b>March 2013</b>
2.06.....	Edition 12 ....	revision 5 - .....	March 2002
2.07.....	Edition 12 ....	revision 4 - .....	June 2001
2.08 to 2.10.....	Edition 12 ....	<b>revision 7 - ....</b>	<b>March 2013</b>
3.01.....	Edition 12 .....		May 1990
3.02.....	Edition 12 ....	revision 4 - .....	June 2001
3.03.....	Edition 12 ....	revision 5 - .....	March 2002
3.04 to 3.05.....	Edition 12 ....	revision 4 - .....	June 2001
3.06.....	Edition 12 ....	revision 5 - .....	March 2002
3.07 to 3.10.....	Edition 12 .....		May 1990
4.01 to 4.04.....	Edition 12 .....		May 1990
4.05.....	Edition 12 ....	revision 4 - .....	June 2001
4.06.....	Edition 12 ....	revision 5 - .....	March 2002
4.07.....	Edition 12 ....	revision 4 - .....	June 2001
4.08 to 4.09.....	Edition 12 .....		May 1990
4.10.....	Edition 12 ....	revision 2 - .....	March 1995
4.11.....	Edition 12 ....	revision 4 - .....	June 2001
4.12.....	Edition 12 ....	revision 2 - .....	March 1995
4.13.....	Edition 12 ....	revision 5 - .....	March 2002
4.14.....	Edition 12 ....	revision 4 - .....	June 2001

LIST OF PAGES

5.01 to 5.02.....	Edition 12 .... revision 2 - .....	March 1995
5.03.....	Edition 12 .... revision 5 - .....	March 2002
5.04.....	Edition 12 .... revision 2 - .....	March 1995
5.05.....	Edition 12 .... revision 4 - .....	June 2001
5.06.....	Edition 12 .... revision 5 - .....	March 2002
5.07 to 5.08.....	Edition 12 .... revision 2 - .....	March 1995
6.01.....	Edition 12 ....	May 1990
6.02.....	Edition 12 .... <b>revision 7 - .....</b>	<b>March 2013</b>
6.03 to 6.04.....	Edition 12 ....	May 1990
7.01.....	Edition 12 .... <b>revision 7 - ...</b>	<b>March 2013</b>
7.02 to 7.06.....	Edition 12 .... revision 2 - .....	March 1995
7.07 to 7.12.....	Edition 12 .... <b>revision 7 - ...</b>	<b>March 2013</b>
7.13 to 7.18.....	Edition 12 .... revision 2 - .....	March 1995
7.19 to 7.20.....	Edition 12 .... revision 3 - ...	October 1997
7.21 to 7.23.....	Edition 12 .... revision 5 - .....	March 2002
7.24 to 7.56.....	Edition 12 .... revision 4 - .....	June 2001

LIST OF REVISIONS

Nr	DESCRIPTION	MODIFIED PAGES	DATE OF APPROVAL
1	<ul style="list-style-type: none"> <li>• Instrument pannel layout</li> <li>• Corrections</li> </ul>	- 0.02; 1.10; 1.11; 1.13 - 1.12; 2.05	05 February 1992
2	<ul style="list-style-type: none"> <li>• Corrections</li> <li>• Noise measurement operation placards.</li> <li>• Auxilliary fuel tank.</li> <li>• Night VFR.</li> <li>• Towing procedure</li> </ul>	- Cover page, i, ii, iii,, - 0.01 to 0.06; 1.05; 1.07 to 1.12; 1.13; 2.01, - 2.05 to 2.10; 4.05, - 4.10 to 4.12; 6.02; - 7.01 to 7.18	24 March 1995
3	<ul style="list-style-type: none"> <li>• Supplement 4: low voltage</li> <li>• Supplement 5: GPS</li> </ul>	- i, ii, iii, 7.01, 7.19 to 7.20 - 7.21 to 7.24	15 October 1997
4	<ul style="list-style-type: none"> <li>• Corrections</li> <li>• Addition of Lycoming O-360 A1P Engine</li> <li>• Supplement 5: GPS</li> <li>• Supplement 6: S-TEC 55 Autopilot.</li> <li>• Supplement 7: Sensenich 76EM895-0-58 propeller</li> <li>• Supplement 8: IFR</li> </ul>	- Cover page, ii, iii, 0.03, 1.07, 1.09, 1.12, 2.06, 2.07, 3.02 to 3.06, 4.05 to 4.07, 4.11, 4.13, 4.14, 5.03, 5.05, 5.06, 7.01, 7.07 to 7.10 - 1.05 - 7.21 to 7.24 - 7.25 to 7.44 - 7.45 to 7.48 - 7.49 to 7.56	22 March 2002
5	<ul style="list-style-type: none"> <li>• Corrections</li> <li>• New pages</li> <li>• Supplement 5 GPS Corrections, GNS 430</li> <li>• Supplement 9: S-TEC 20 &amp; 30 autopilot</li> <li>• Supplement 10: electrical elevator trim</li> </ul>	- Cover page, ii, iii, 2.06, 3.03, 3.06, 4.06, 4.13, 5.03, 5.06, 7.01 - iv, v - 7.21 to 7.23 7.57 to 7.66 - 7.67 to 7.70	28 MARCH 2002

## LIST OF REVISIONS

<i>Nr</i>	<i>Description</i>	<i>Modified pages</i>	<i>Date of approval</i>
6	Modified pages	Cover page, ii, iii, v, 7.01	23 March 2005
	Supplement 9: withdrawn	7.57 to 7.66	
	Supplement 10: withdrawn	7.67 to 7.70	
7	Manufacturer details	First page	AFM APPROVAL EASA 10044946 22 May 2013
	Updating	ii, iii, v	
	Electric schematic inserted	1.05 to 1.07	
	Fuel weight, placards	2.05, 2.08 to 2.10	
	Updating of weight & balance diagram	6.02	
Supplement 2 withdrawn	7.01, 7.07 to 7.12		



TABLE OF CONTENTS

List of abbreviations used .....	0.02
List of radio abbreviations .....	0.03
Conversion factors .....	0.04
Barometric Pressure Conversion table .....	0.05

LISTE DES ABREVIATIONS UTILISEES

sq ft.....	Square foot
ft.....	Foot
in.....	Inches
Nm.....	Nautic mile
km.....	Kilometer
m.....	Meter
cm.....	Centimeter
kt.....	Knot
m/s.....	Meter per second
tr/mn ou rpm ...	Rotation per minute
Va.....	Maneuvering speed
VC.....	Calibrated air speed
Vfe.....	Maximum flaps extended speed
Vne.....	Never exceed speed
Vno  .....	Maximum cruising speed
Vso.....	Stalling speed landing configuration
Vs1.....	Stalling speed flaps up position
VI.....	Indicated air speed
km/h.....	Kilometer per hour
HP.....	Horse Power
hPa.....	Hectopascal
in.Hg.....	Inches of mercury
mbar.....	Millibar
Zp.....	Pressure altitude
l.....	Liter
imp gal.....	Imperial gallon
us gal.....	US gallon
psi.....	Pound per square inch
lb.....	Pound
kg.....	Kilogramme
°C.....	Degrees Centigrade
°F.....	Degrees Farenheit
V.....	Volt
A.....	Ampere

LIST OF RADIO ABBREVIATIONS

ADF .....	Automatic Direction Finder
ATC .....	Air Traffic Control
COM .....	Communication Transceiver
DME .....	Distance Measuring Equipment
ELT .....	Emergency Locator Transmitter
ILS .....	Instrument Landing System
MKR .....	Marker Beacon Receiver
NAV .....	Navigation Indicator and Receiver
AUDIO .....	Audio Control Panel
VFR .....	Visual Flight Rules
IFR .....	Instrument Flight Rules
VHF .....	Very High Frequency
VOR .....	VHF Omni-Range

CONVERSION FACTORS

nautical miles.....	X.....	1.852.....	= ... kilometers
feet.....	X.....	0.305.....	= ... meters
inches.....	X.....	0.0254.....	= ... meters
inches.....	X.....	25.4.....	= ... millimeters
feet/minut.....	X.....	0.00508 .....	= ... meter/second
gallons (US).....	X.....	3.785.....	= ... liters
gallons (Imp).....	X.....	4.546.....	= ... liters
quarts (US).....	X.....	0.946.....	= ... liters
knots.....	X.....	1.852.....	= ... km/h
psi.....	X.....	0.0689.....	= ... bar
in.Hg.....	X.....	33.86.....	= ... mbar
lb.....	X.....	0.453.....	= ... kg
(°F - 32).....	X.....	5/9.....	= ... °C

kilometers.....	X.....	0.539.....	= ... nautical miles
meters.....	X.....	3.281.....	= ... feet
meters.....	X.....	39.37.....	= ... inches
millimeters.....	X.....	0.03937 .....	= ... inches
meter/second.....	X.....	197.....	= ... feet/minut
liters.....	X.....	0.264.....	= ... gallons (US)
liters.....	X.....	0.220.....	= ... gallons (Imp)
liters.....	X.....	1.057.....	= ... quarts (US)
km/h.....	X.....	0.539.....	= ... knots
bar.....	X.....	14.51.....	= ... psi
mbar.....	X.....	0.02953 .....	= ... in.Hg
kg.....	X.....	2.205.....	= ... lb
°C.....	X.....	9/5 + 32 .....	= ... °F



**BAROMETRIC PRESSURE CONVERSION TABLE**

Below pressure in MILLIBAR or HECTOPASCAL the pressure in INCHES of MERCURY is indicated.

→ mbar or hPa  
 → in. Hg

950	960	970	980	990	1000	1010	1020	1030	1040
28.05	28.35	28.64	28.94	29.23	29.53	29.63	30.12	30.42	30.71
951	961	971	981	991	1001	1011	1021	1031	1041
28.08	28.38	28.67	28.97	29.26	29.56	29.85	30.15	30.45	30.74
952	962	972	982	992	1002	1012	1022	1032	1042
28.11	28.41	28.70	29.00	29.29	29.59	29.88	30.18	30.47	30.77
953	963	973	983	993	1003	1013	1023	1033	1043
28.14	28.44	28.73	29.03	29.32	29.62	29.91	30.21	30.50	30.80
954	964	974	984	994	1004	1014	1024	1034	1044
28.17	28.47	28.76	29.06	29.35	29.65	29.94	30.24	30.53	30.83
955	965	975	985	995	1005	1015	1025	1035	1045
28.20	28.50	28.79	29.09	29.38	29.68	29.97	30.27	30.56	30.86
956	966	976	986	996	1006	1016	1026	1036	1046
28.23	28.53	28.82	29.12	29.41	29.71	30.00	30.30	30.59	30.89
957	967	977	987	997	1007	1017	1027	1037	1047
28.26	28.56	28.85	29.15	29.44	29.74	30.03	30.33	30.62	30.92
958	968	978	988	998	1008	1018	1028	1038	1048
28.29	28.58	28.88	29.18	29.47	29.77	30.06	30.36	30.65	30.95
959	969	979	989	999	1009	1019	1029	1039	1049
28.32	28.61	28.91	29.20	29.50	29.80	30.09	30.39	30.68	30.98

**REMINDER:**

The standard pressure of 1013.2 mbar or hPa equals 29.92 in.Hg

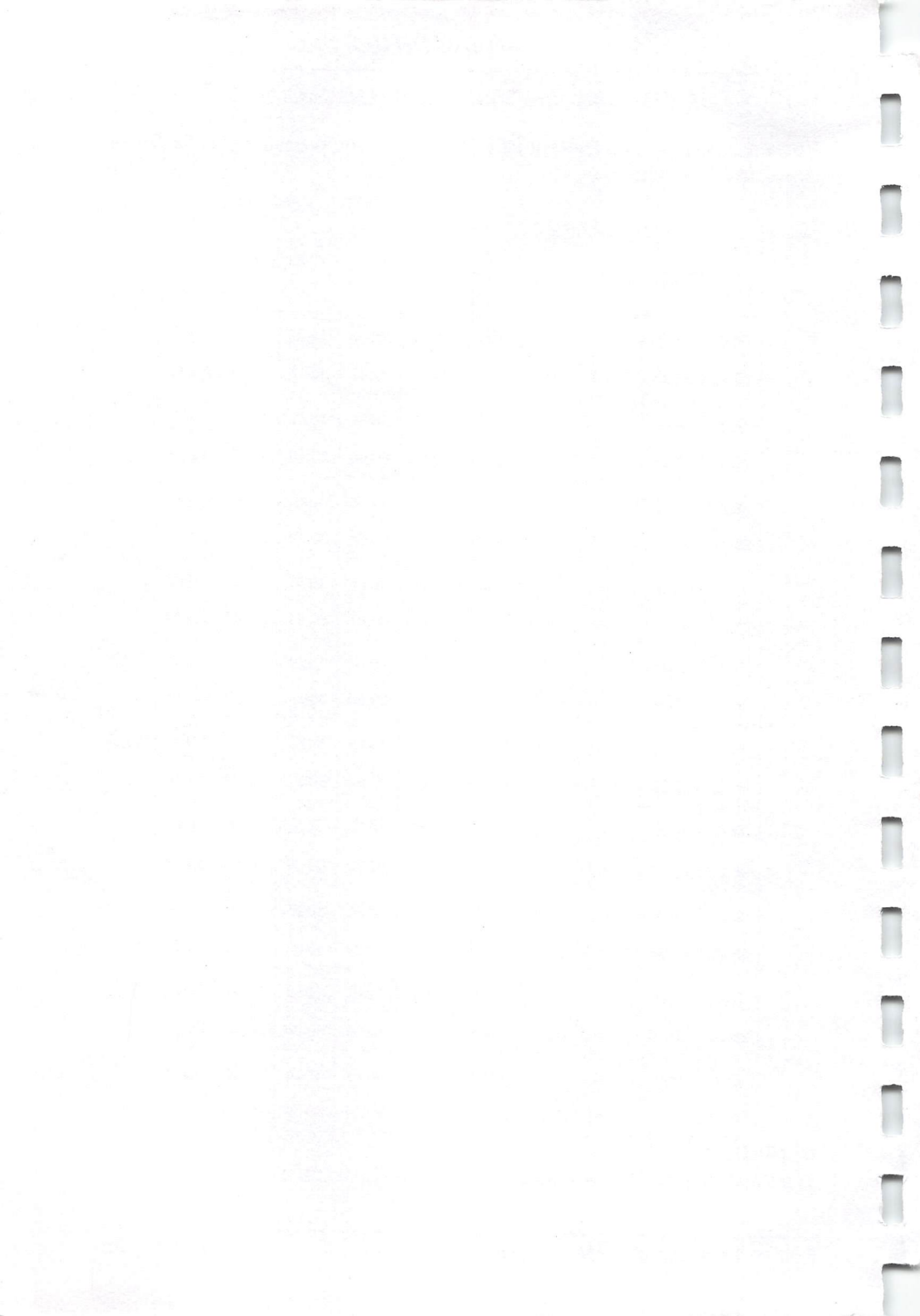

SECTION 1	DESCRIPTION
-----------	-------------

TABLE OF CONTENTS

Aircraft dimensions .....	1.03
Internal cabin dimensions.....	1.03
Wings .....	1.03
Ailerons .....	1.03
Wing flaps.....	1.04
Horizontal stabilizer .....	1.04
Vertical stabilizer .....	1.04
Landing gear .....	1.04
Brakes .....	1.05
Powerplant .....	1.05
Electrical circuit 40 A type .....	1.06
Electrical circuit 60 A type .....	1.07
Fuel .....	1.08
Oil.....	1.08
Fuel system diagram .....	1.09
Instrument panel.....	1.10
Heating & ventilating system .....	1.12

# FLIGHT MANUAL DR400/180

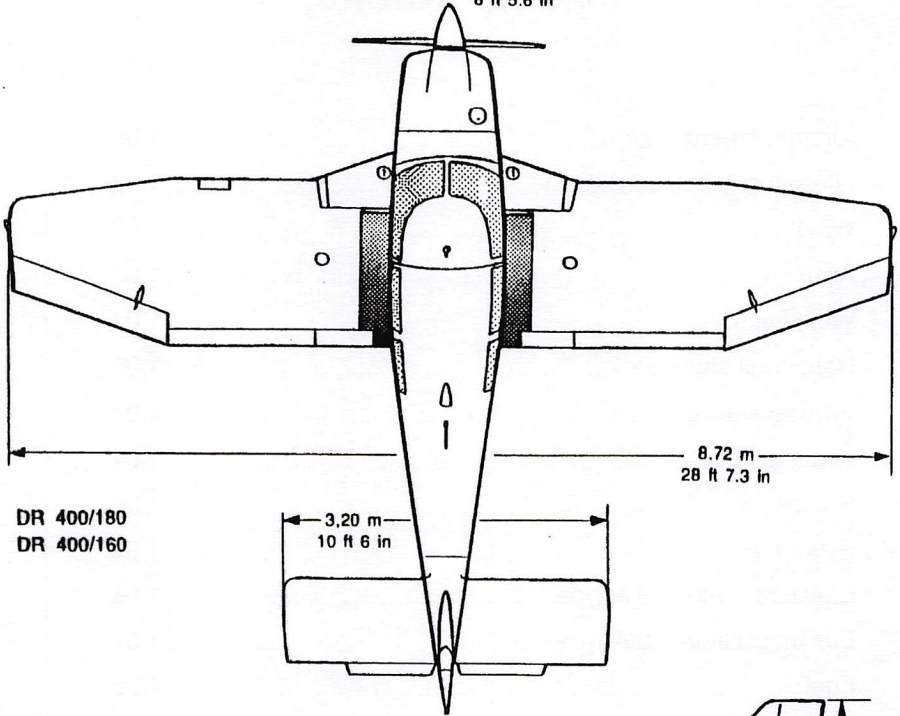
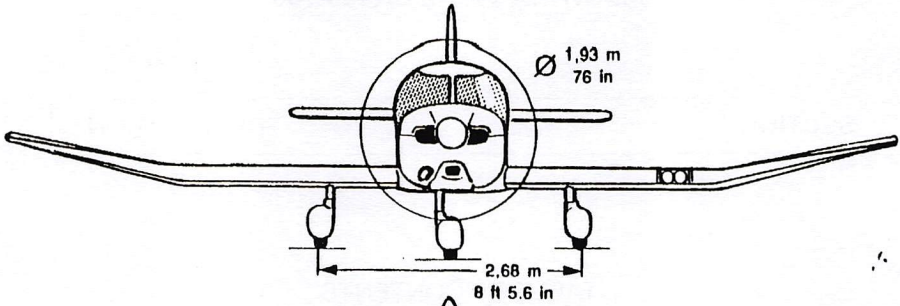

DR 400/180  
DR 400/160

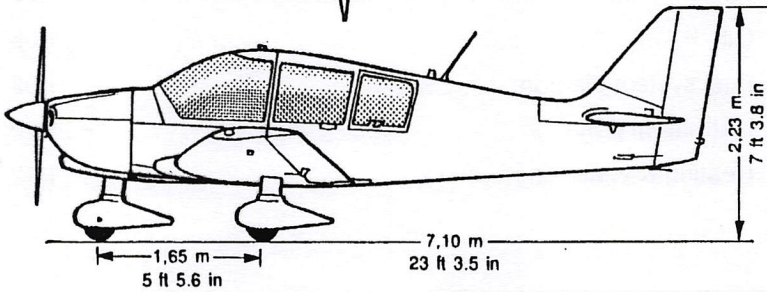



**OVERALL DIMENSIONS**

Wing span .....	(28 ft 7.3 in)	8.72 m
Overall length .....	(23 ft 3.5 in)	7.10 m
Overall height .....	(7 ft 3.8 in)	2.23 m
Propeller ground clearance .....	(9.84 in)	0.25 m

**INTERNAL CABIN DIMENSIONS**

Length .....	(5 ft 3.8 in)	1.62 m
Width .....	(3 ft 7.3 in)	1.10 m
Height .....	(4 ft 0.4 in)	1.23 m

4 seats, accessible from both sides by sliding canopy.

**WINGS**

Wing area .....	(152.86 sq ft)	14.2 m <sup>2</sup>
Airfoil .....	NACA 23013.5 modified	
Aspect ratio .....	5.35	
Dihedral at wing tips .....	14°	

**AILERONS (each)**

Surface .....	(6.13 sq ft)	0.57 m <sup>2</sup>
Span .....	(5 ft 3.8 in)	1.62 m

The ailerons are statically balanced.

**WINGS FLAPS (each)**

Surface ..... (3.55 sq ft) 0.33 m<sup>2</sup>  
Span ..... (6 ft 7.7 in) 2.02 m

**HORIZONTAL STABILIZER**

Total control surface ..... (31 sq ft) 2.88 m<sup>2</sup>  
of which antibalance tab ..... (2.8 sq ft) 0.26 m<sup>2</sup>  
Span ..... (10 ft 6 in) 3.20 m

**VERTICAL STABILIZER**

Surface overall ..... (17.55 sq ft) 1.63 m<sup>2</sup>  
Stabilizer ..... (10.76 sq ft) 1 m<sup>2</sup>  
Rudder ..... (6.78 sq ft) 0.63 m<sup>2</sup>

**LANDING GEAR**

**Fixed Tricycle Type**

Track ..... (8 ft 5.6 in) 2.58 m  
Wheel base ..... (5 ft 5 in) 1.65 m  
Tyre size ..... 380 x 150

Oil, shock struts : MIL. H. 5606 - A

Norme AIR 3520

**Nose Gear**

Tyre pressure ..... (26.1 psi) 1.8 bar  
Shock strut pressure ..... (72.55 psi) 5 bar

## FLIGHT MANUAL DR400/180

### Main landing gear

Tyre pressure .....(29 psi) 2 bar  
Shock strut pressure .....(87 psi) 6 bar

### BRAKES

The disc brakes are operated by an independent hydraulic circuit on each main gear wheel.

Hydraulic oil.....MIL H 5606-A  
AIR 3520 standard

### POWERPLANT

#### Engine

Manufacturer .....LYCOMING  
Type ..... O-360-A3A or O-360 A1P  
Number of cylinders ..... 4  
Maximum continuous power..... 180 HP at 2700 tr/min

#### Propeller

MANUFACTURER	SENENICH
TYPE	76 EM8 S5-0-64
DIAMETER	1,93 m (76 in)*
PITCH	64 in
MINIMAL STATIC RPM FULL THROTTLE SEA LEVEL	2200

\* Any reduction in diameter during repair is forbidden.

#### NOTE

**Avoid continuous engine speed use  
between 2150 rpm and 2350 rpm**

ELECTRICAL CIRCUIT - 40 A type

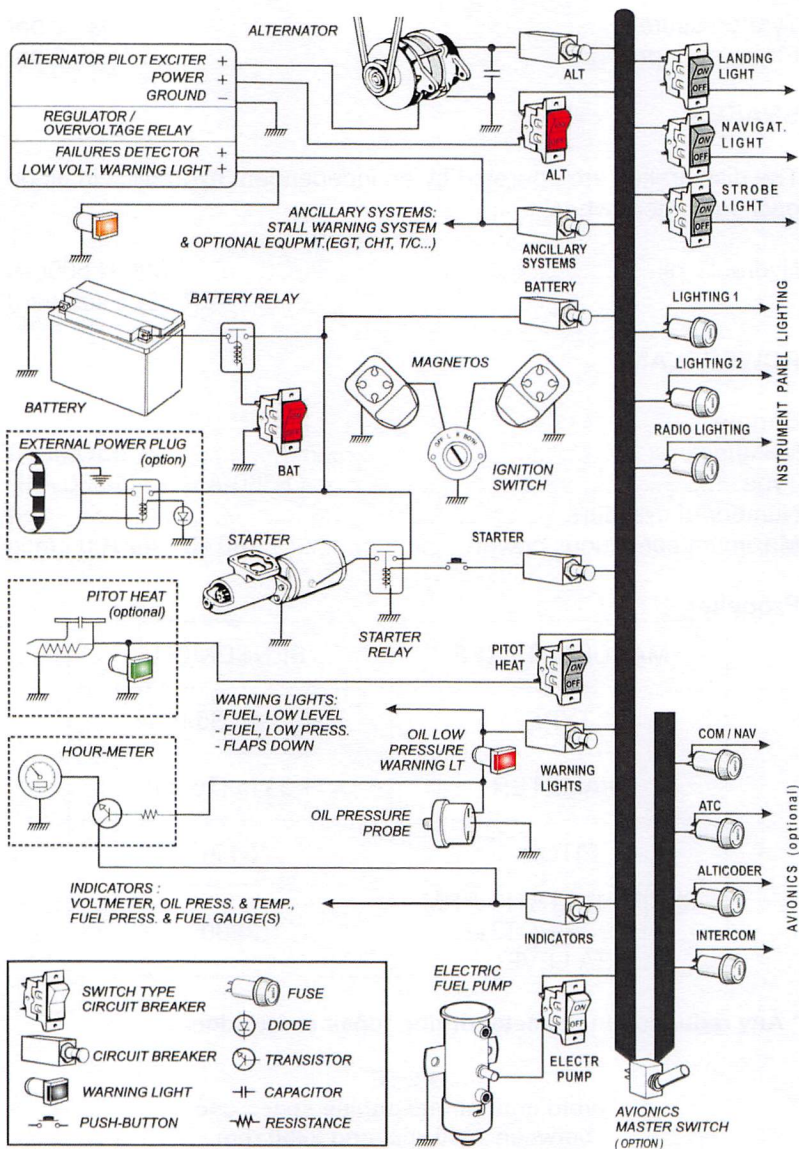



**ELECTRICAL CIRCUIT - 60 A type**

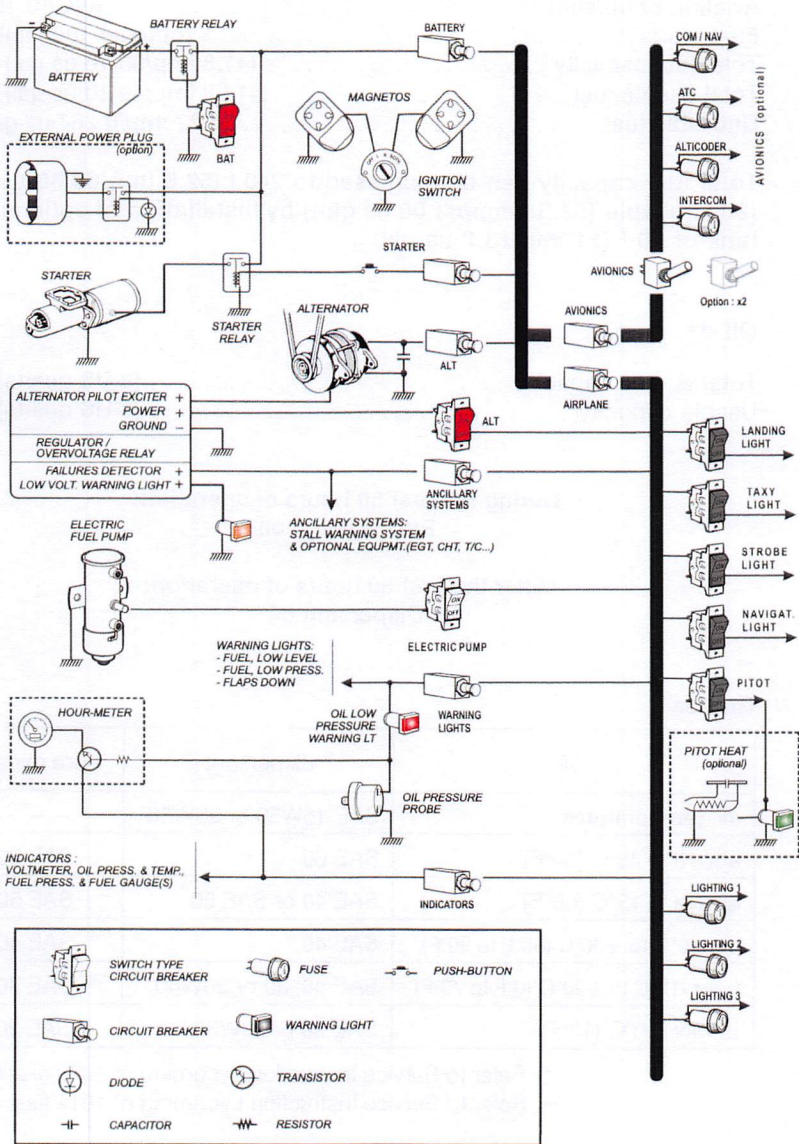

**FUEL**

Aviation petroleum \* ..... AVGAS 100 LL  
 Fuel grade \* ..... (octane) 100 minimum  
 Total fuel capacity ..... (41.8 imp/50.16 us gal) 190 l  
 Total usable fuel ..... (41.58 imp/49.10 us gal) 189 l  
 Unusable fuel ..... (0.22 imp/0.264 us gal) 1 l

Total fuel capacity can be increased to 240 l (52.8 imp/63.36 us gal) (239 l usable (52.58 imp/63.09 us gal)) by installation of optional fuel tank of 50 l (11 imp/13.2 us gal).

**OIL \*\***

Total engine capacity ..... (8 US quarts) 7.5 l  
 Usable capacity ..... (6 US quarts) 5.7 l

**During the first 50 hours of operation:**

**Pure mineral oil**

**After the first 50 hours of operation:**

**Dispersant oil**

**Grades**

Oil	dispersant	pure mineral
all temperatures	SAE 15W50 or 20W50	-----
above + 25°C (80°F)	SAE 60	SAE 60
above + 15°C (60°F)	SAE 40 or SAE 50	SAE 50
from 0°C to +30°C (30°F to 90°F)	SAE 40	SAE 40
from -15°C to +20°C (0°F to 70°F)	SAE 40, 30 or 20W40	SAE 30
below -10°C (10°F)	SAE 30 or 20W30	SAE 20

\* Refer to Service Instruction Lycoming n° 1070 (last issue).

\*\* Refer to Service Instruction Lycoming n° 1014 (last issue).



FUEL SYSTEM DIAGRAM

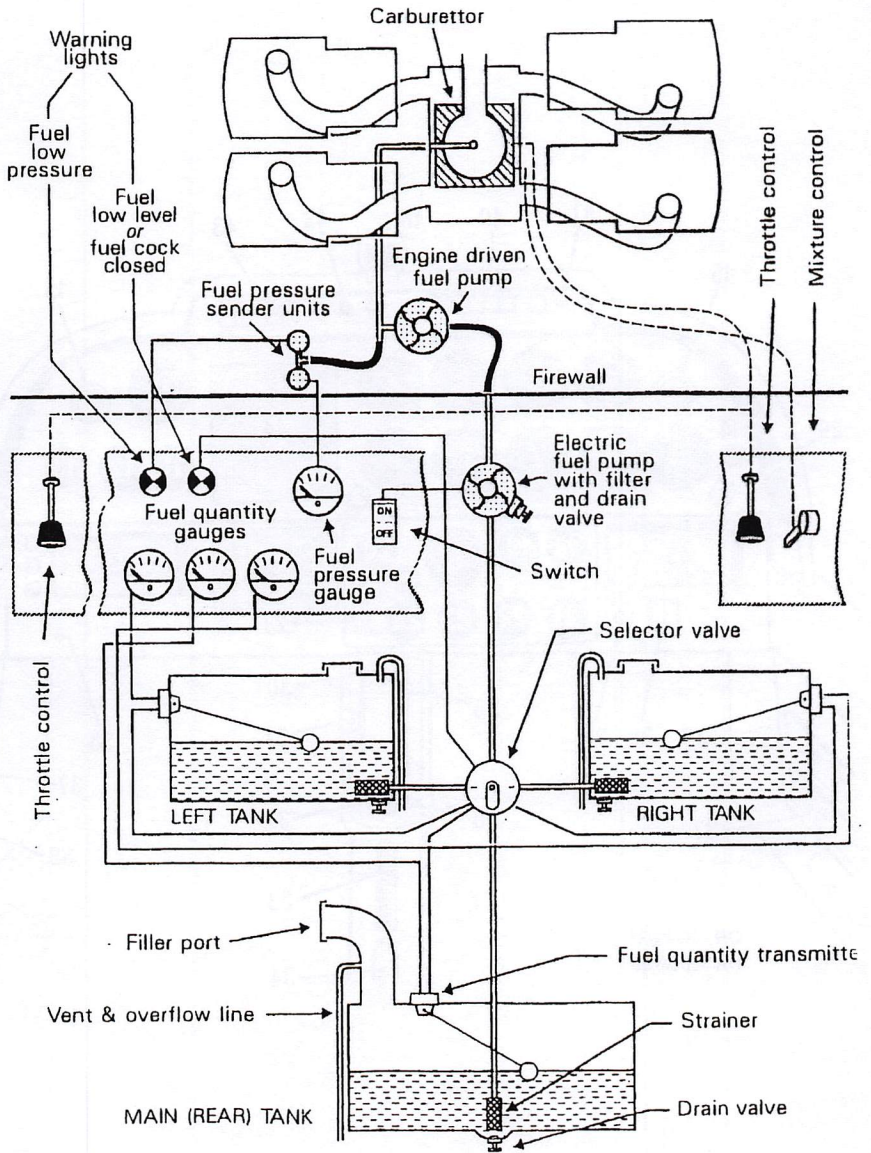

INSTRUMENT PANEL

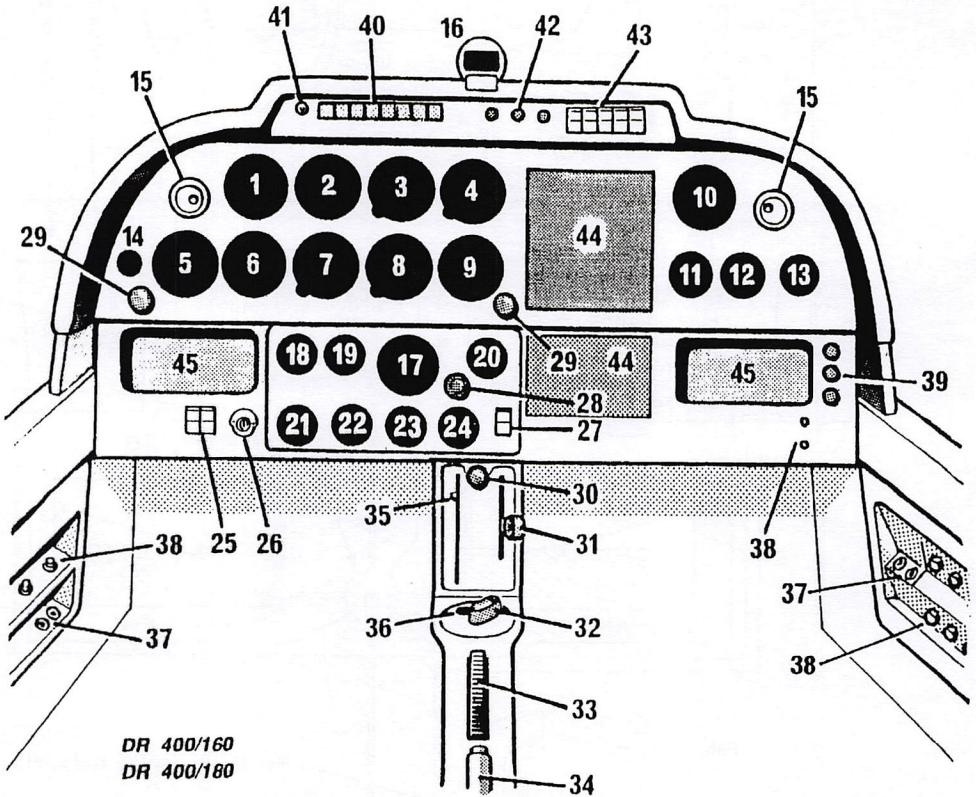

- |         |                                  |         |                                     |
|---------|----------------------------------|---------|-------------------------------------|
| 1.....  | Airspeed indicator               | 30..... | Parking brake locking control       |
| 2.....  | Gyro horizon (option)            | 31..... | Mixture lever friction control      |
| 3.....  | Altimeter                        | 32..... | Fuel cock                           |
| 4.....  | Optional equipment               | 33..... | Elevator trim tab control wheel     |
| 5.....  | Optional equipment               | 34..... | Flap control lever                  |
| 6.....  | Turn and bank indicator (option) | 35..... | Trim tab position indicator         |
| 7.....  | Directional gyro (option)        | 36..... | Starter push button                 |
| 8.....  | Rate of climb indicator (option) | 37..... | Mike, Headset-Jack sockets (option) |
| 9.....  | Optional equipment               | 38..... | Fuses                               |
| 10..... | Optional equipment               | 39..... | Cabin heat control                  |
| 11..... | Optional equipment               | 40..... | Annunciator panel (from L to R):    |
| 12..... | Optional equipment               |         | - oil pressure                      |
| 13..... | Optional equipment               |         | - fuel pressure                     |
| 14..... | Vacuum gauge (option)            |         | - fuel low level                    |
| 15..... | Cabin vent                       |         | - alternator load                   |
| 16..... | Magnetic compass                 |         | - flaps extended                    |
| 17..... | Tachometer                       |         | - pitot heat (option)               |
| 18..... | Oil pressure gauge               |         | - towing cable secured              |
| 19..... | Oil temperature gauge            | 41..... | Day/night lighting selector         |
| 20..... | Fuel pressure gauge              | 42..... | Instrument panel lighting           |
| 21..... | Voltmeter                        | 43..... | Switch type circuit breaker         |
| 22..... | Fuel gauge                       |         | (from L to R):                      |
| 23..... | Optional equipment               |         | - taxi lights (option)              |
| 24..... | Cylinder head temperature (CHT)  |         | - landing lights (option)           |
| 25..... | Switch type circuit breaker      |         | - strobe lights (option)            |
|         | (Battery, Alternator)            |         | - navigation lights (option)        |
| 26..... | Magneto switch                   |         | - pitot heat (option)               |
| 27..... | Safety switch (electric pump)    | 44..... | Radio equipment (option)            |
| 28..... | Carburetor heat control          | 45..... | Storage box (or optional            |
| 29..... | Throttle                         |         | equipment)                          |



# HEATING & VENTILATION SYSTEM

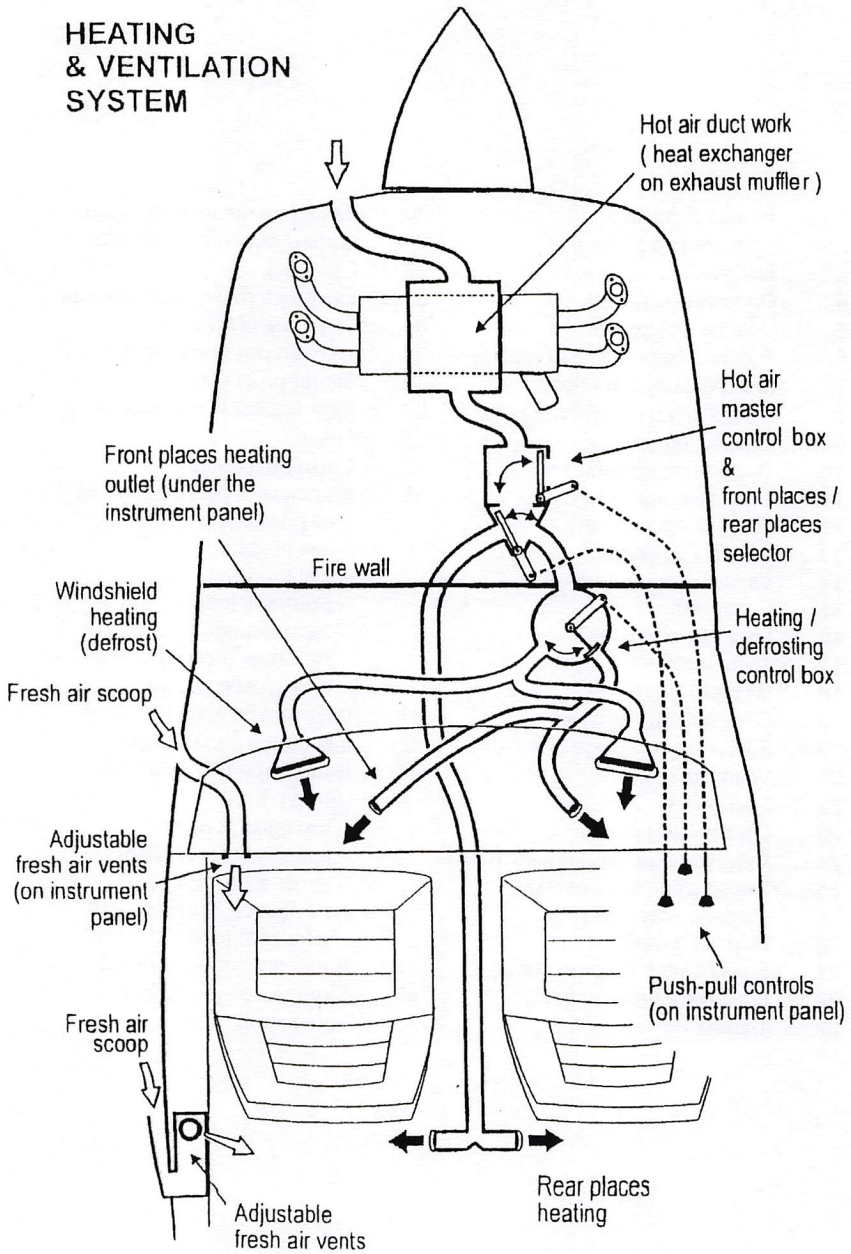

TABLE OF CONTENTS

Certification standards .....	2.03
Approved operation .....	2.03
Airspeed limitations .....	2.03
Airspeed indicator markings .....	2.03
Flight load factor limits at gross weight .....	2.04
Balance .....	2.04
Loading limits .....	2.04
Load planning .....	2.05
Engine limitations .....	2.06
Operational limitations .....	2.07
Operation placards .....	2.08



**NOTE**

All speeds in this manual are indicated  
Air speeds unless otherwise specified

### CERTIFICATION STANDARDS

The DR 400/180 aircraft has been certified on the 10.05.72 in the "NORMAL" and "UTILITY" category conforming to the following technical conditions :

- General conditions of regulation AIR 2050 updated 6 June 1966.
- Complementary conditions for conformity with FAR part 23 - Amendment 7.
- Special conditions relative to the cockpit canopy release.

### APPROVED OPERATION

VFR by day, in non-icing conditions

AIRSPEED LIMITATIONS	km/h	(kt)
Vne never exceed	308	(166)
Vno max. cruise	260	(140)
Va max. maneuver	215	(116)
Vfe max. flaps extended	170	(92)

AIRSPEED INDICATOR MARKINGS		km/h	kt
Red line-never exceed	Vne	308	166
Yellow arc operate with caution and only in "smooth air"	Vno - Vne	260 - 308	140 - 166
Green arc normal operation range	Vs1 - Vno	105 - 260	56 - 140
White arc	Vso - Vfe	95 - 170	51 - 92

**LOAD FACTOR LIMITS AT GROSS WEIGHT**

(2095 lb) 950 kg (category "U")

Flaps up ..... n between + 4.4 and -2.2

Flaps down ..... n = +2

(2425 lbs) 1100 kg (category "N")

Flaps up ..... n between + 3.8 and -1.9

Flaps down ..... n = +2

**MAXIMUM AUTHORIZED WEIGHTS**

	Cat. "U"	Cat. "N"
On take off .....	(2095 lb) 950 kg	(2425 lb) 1100 kg
On landing .....	(2095 lb) 950 kg	(2304 lb) 1045 kg

**WEIGHT AND BALANCE**

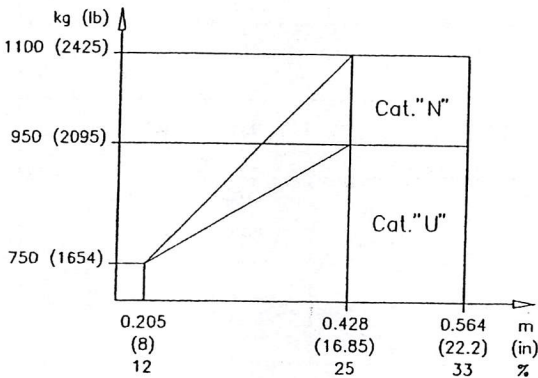

Levelling ..... Upper fuselage longeron  
 Datum ..... wing leading edge, rectangular section  
 Chord line ..... (67.3 in) 1.71 m

**LOAD PLANNING**

(Refer also to weight and balance chart, section 6).

The weight of engine oil, as well as the unusable fuel, must be included in the empty weight of the aircraft.

	Weight kg (lb)	Arm m (in)
Front seats	2 x 77 (2 x 170)	0.36 - 0.46 (14) – (18)
Rear seats (*)	2 x 77 (2 x 170)	1.19 (47)
Fuel Main fuselage tank	78.5 (173)	1.12 (44)
Fuel Wing tanks	57.6 (127)	0.1 (3.9)
Baggage (**)	60 (132)	1.9 (75)

\*\* Within the authorized weight and balance limits.

\* The carriage of more than two passengers (with a total weight below or equal to the maximum indicated) is authorized on the rear bench, provided that passenger seat belts are installed for each passenger, and that weight and balance are within the stated limits.

## ENGINE LIMITATIONS

Continuous starter operation.....15 to 20 sec  
Max. rpm (red line).....2700 rpm  
Max. cylinder head temperature (red line) if equipped.....(500°F) 260°C

## TACHOMETER MARKINGS

Red arc.....2150 to 2350 rpm  
Green arc.....2350 to 2700 rpm  
Red line.....2700 rpm

## FUEL

Aviation petroleum\*.....AVGAS 100 LL  
Grade\*.....(octane) 100 minimum  
Maximum total capacity.....(41.8 imp/50.16 us gal) 190 l  
Usable total capacity.....(41.58 imp/49.10 us gal) 189 l  
Unusable capacity.....(0.22 imp/0.264 us gal) 1 l  
Normal pressure.....(1.1 to 5 psi) 80 to 350 mbar

Total fuel capacity can be increased to 240 l (52.8 imp/ 63.36 us gal)  
(239 l usable (52.58 imp/63.09 us gal) by the installation of auxiliary fuel  
tank of 50 l (11 imp/13.2 us gal).

## OIL

Maximum temperature (red line).....(245°F) 118°  
Normal temperature (green arc).....(140 TO 245°F) 60 to 118°C  
Normal pressure (green arc).....(55 to 95 psi) 3.8 to 6.5 bar  
Minimum idle pressure (red line).....(25 psi) 1.70 bar  
Maximum pressure (red line).....(115 psi) 7.9 bar  
Total engine capacity.....(8 US quarts) 7.5 l  
Usable capacity.....(6 US quarts) 5.7 l  
Grades.....see page 1.08

\* Refer to Service Instruction Lycoming n°1070 (last issue).



**LOAD LIMITS**

Number of occupants:

Front seats ..... 2  
Rear seats ..... 2

Baggage compartment:

Maximum authorized weight ..... (132 lb) 60 kg

**OPERATIONAL LIMITATIONS IN THE "U" CATEGORY**

Within the limits of this category, the following manoeuvres are authorized:

- Steep turns, lazy eights, chandelles in which the angle of bank is more than 60°.
- Stalls (except whip stalls).

These manoeuvres must be carried out within the conditions below:

- The rear seats must be unoccupied
- Entry and exit speeds must be within the normal operating range
- Recommended entry speed: (116 kt) 215 km/h

## **PLACARDS**

The following information is displayed in the form of composite or individual placards.

In clear view of the pilot:

"THIS AIRCRAFT MUST BE USED FOR NORMAL OR UTILITY FLYING, ONLY IN ACCORDANCE WITH THE APPROVED FLIGHT MANUAL"

"ON THIS AIRCRAFT, ALL INDEXES, MARKINGS AND PLACARDS CORRESPOND TO NORMAL UTILISATION"

"FOR UTILITY OPERATION, REFER TO THE APPROVED FLIGHT MANUAL"

"AEROBATICS, INCLUDING SPINS ARE PROHIBITED WHEN USED IN NORMAL CATEGORY"

"VA MANEUVERING SPEED: 215 km/h – 116 kt"

"APPROVED FOR VFR FLIGHT BY DAY IN NON-ICING CONDITIONS ONLY"

"NO SMOKING"

In the baggage bay:

"BAGGAGE BAY MAX. LOAD 60 kg – SEE LOADING DIAGRAM"

Near the main tank filler port:

"AVGAS 100LL 110 liters"

Near the wing tanks filler ports:

"AVGAS 100LL 40 liters"

On each main gear wheel fairing:

"MAIN GEAR

TYRE 2 bar /29 psi      SHOCK ABSORB. 6 bar / 87 psi"

On the front gear wheel fairing:

"NOSE GEAR

TYRE 1.8 bar / 26 psi      SHOCK ABSORB. 5 bar / 73 psi"

## FLIGHT MANUAL DR400/180

On the hydraulic fluid reservoir:

“HYDRAULIC FLUID

AIR 3520

MIL. H.5606-A

SHELL FLUID 4

BP Hydraulic 1 (Aero)

Under the oil dip access door located on the engine cowling

<b>AVIATION OIL</b>	<b>DISPERSANT</b>		<b>MINERAL</b>	
	<b>SAE</b>	<b>GRADE</b>	<b>SAE</b>	<b>GRADE</b>
<b>ALL TEMPERATURE</b>	15W40 20W50			
<b>ABOVE +25°C (80°F)</b>	60	120	60	120
<b>ABOVE +15°C (60°F)</b>	40 ou 60	80 ou 100	50	100
<b>0°C to +30°C (30°F à 90°F)</b>	40	80	40	80
<b>-15°C to +20°C (0°F à 70°F)</b>	40, 30 ou 20W40	80 ou 65	30	65
<b>BELOW - 10°C (10°F)</b>	30 ou 20W40	65	20	55
<b>See Lycoming Service Instruction n° 1014 for more information</b>				

Page intentionally left blank

**SECTION 3**

**EMERGENCY PROCEDURES**

**TABLE OF CONTENTS**

Engine failure during take off roll .....	3.02
Engine failure Immediately after take off .....	3.02
Engine failure In flight .....	3.03
Power off forced landing off airfield .....	3.03
Precautionary power landing off airfield .....	3.04
Fire .....	3.04
Vibrations and roughness engine operation .....	3.06
Low oil pressure .....	3.06
Icing .....	3.07
Electrical power supply malfunction .....	3.08
Inadvertent spins .....	3.08
Loss of elevator control .....	3.09



## ENGINE FAILURE DURING TAKE OFF ROLL

### With sufficient runway remaining:

Throttle to idle, and stop in the runway axis using brakes as required.

### Without sufficient runway remaining:

Throttle	idle
Brakes	apply heavily
Mixture	cut-off
Fuel valve	off
Magneto switch	off
Battery switch	off

## ENGINE FAILURE IMMEDIATELY AFTER TAKE OFF

Glide speed (flaps in take off position)	(78 kt) 145 km/h
Mixture	cut-off
Fuel valve	off
Magneto switch	off
Battery switch	off

### NOTE CAREFULLY

Land straight ahead, with only small direction changes to avoid obstructions.

Never try to turn back to the runway, as altitude after take off is seldom sufficient.

## ENGINE FAILURE IN FLIGHT

If altitude is evaluated to be sufficient to try an engine restart:

- Establish maximum glide speed, flaps up 150 km/h (81 kt) (in these conditions, and without wind, the aircraft covers approximately 9.3 times its altitude).
- Fuel valve.....open
- Electric pump ..... on
- Mixture .....fully rich
- Throttle..... 1/4 travel forward
- Magneto switch ..... L + R ("Both")

If the propeller still turns, the engine should restart.

If the propeller is stopped, operate the starter.

If the engine still does not start, prepare for a forced landing, following the procedure below.

## POWER OFF FORCED LANDING OFF AIRFIELD

Look for a suitable landing area :

- Belts and harness.....tight
- Electric pump ..... off
- Mixture .....cut-off
- Throttle ..... to idle
- Magneto switch ..... off
- Fuel valve ..... off
- Alternator switch..... off

## Final

- Flaps.....full down
- Battery switch.....off
- Canopy.....unlock

## PRECAUTIONARY POWER LANDING OFF AIRFIELD

Fly over the chosen field several times at low speed 150 km/h (81 kt) in order to locate the most suitable landing area, flaps in "take off" position, then make a precautionary approach at 125 km/h (67 kt), flaps in "landing" position.

On final, unlock the canopy.

### Before touch-down

Magneto switch .....	off
Battery switch .....	off

### NOTE: IN CASE OF CANOPY JAMMING

Canopy handle in "open" position.

Free the two canopy release levers located on the arm rests, on both sides of the instrument panel, and place them in vertical position.

## FIRE

### Engine fire during starting

Keep the engine turning with:

Fuel valve .....	off
Electric pump .....	off
Throttle .....	full power
Mixture .....	cut-off

The aim of this procedure is to make the engine "swallow" the accumulated fuel in the inlet pipes (generally following an excess of fuel injection during a difficult engine start).

**If the fire continues**

- Magneto switch . . . . . off
- Battery switch . . . . . off
- Alternator switch . . . . . off

Abandon the aircraft, and try to extinguish the fire with the aids available: fire extinguishers, covers, clothing or sand.

**Engine fire in flight**

- Fuel valve . . . . . off
- Throttle . . . . . full power until engine stops
- Mixture . . . . . cut-off
- Electric pump . . . . . off
- Alternator switch . . . . . off
- Cabin heat and ventilation . . . . . off
- Establish maximum glide speed . . . . . (81 kt) 150 km/h

Prepare for a forced landing off airfield, following the procedure in the paragraph "Power off forced landing off airfield".

Do not attempt to restart the engine.

**Cabin fire**

Extinguish the fire by all means possible (optional extinguisher).

To eliminate smoke, apply maximum ventilation.

In case of an electrical fire (fumes indicating insulation burning):

- Cabin ventilation . . . . . reduce
- Alternator switch . . . . . off
- Battery switch . . . . . off
- Battery circuit breaker . . . . . pull out
- Alternator circuit breaker . . . . . pull out

Land quickly if the fire continues.



## **VIBRATIONS AND ENGINE ROUGHNESS OPERATION**

Vibrations and engine roughness operation are generally due to (verify in this order):

- Carburetor icing: see paragraph "Icing" on next page
- Mixture set too rich or too lean: adjust the mixture (see section 4)
- Contamination in the fuel system: verify fuel pressure. Switch on the electric pump.
- Ignition failure: magneto switch on "L", then on "R", then return to "Both". Select the position providing the best engine operation, and fly to the nearest airfield with mixture set to obtain the smoothest engine operation possible at reduced power.

## **LOW OIL PRESSURE**

In case of low oil pressure indication, check oil temperature, and if it is too high (red arc):

- Reduce power
- Fly to the nearest airfield, and prepare for an off airfield landing

## ICING

Proceed as follows when inadvertently encountering icing :

- Carburetor heat on.
- Increase power in order to reduce ice built-up to minimum.
- Switch on pitot heat (if installed).
- Select maximum cabin heat, and direct the total output to the windscreen (position "defrost") in order to remove the ice quickly.
- Turn back, or change altitude, to obtain an outside air temperature less conducive to icing.
- Plan to land at the nearest airfield.

With an extremely rapid ice build-up, carry out a forced landing.

Remember that a layer of 0.5 cm (0.2 in) on the wing leading edge fairly increases stall speed. If needed, use a higher than normal approach speed : 145 km/h (78 Kt).

## REMARKS

If continuous carburetor heat is deemed necessary, it is imperative to adjust the mixture control to obtain normal engine operation.

Always use carburetor heat fully on or fully off, in certain cases, an intermediate position could increase icing.

## ELECTRICAL POWER SUPPLY MALFUNCTION

Alternator failure is indicated when the amber "alternator failure" light on the warning panel is lit, and a progressive drop in voltage (shown on the voltmeter).

### If "alternator failure" is lit

- Switch off alternator, then back on.  
This operation resets the overvoltage relay which may have cut-out due to a transient overvoltage.

### If the failure continues

- Switch off the alternator
- Switch off all electrical equipment not essential for continuing the flight
- Land as soon as possible, and have the electrical system inspected.

#### NOTE

An alternator failure does not prevent the engine from operating normally.

## INADVERTENT SPIN

Should a spin occur, use the following procedure :

- Throttle ..... idle
- Rudder ..... maximum opposite to direction of rotation
- Elevator ..... neutral
- Ailerons ..... neutral
- Once rotation stops, rudder to neutral position and recover within flight limitations.

#### NOTE

If flaps are down when spin begins, retract them immediately.

## **LOSS OF ELEVATOR CONTROL**

In the event of loss of elevator control (accidental disconnection)

- Stabilize the aircraft in level flight, flaps up, at 150 km/h (81 kt), using the elevator trim and throttle.
- Do not change the elevator trim setting, and control the angle of descent only with throttle.

Reduce power only on short final, and near to the ground.



PAGE INTENTIONALLY LEFT BLANK

SECTION 4

NORMAL PROCEDURES

TABLE OF CONTENTS

Loading .....	4.03
Normal operating speeds.....	4.03
Preflight inspection .....	4.04
Cabin interior check prior start-up .....	4.06
Starting engine .....	4.06
After engine start .....	4.07
Taxiing .....	4.08
Engine run-up .....	4.08
Before take off .....	4.09
Take off .....	4.09
Climb .....	4.10
Cruise .....	4.10
Descent .....	4.12
Landing .....	4.12
Engine shut-down .....	4.13
Parking brake use .....	4.14

PAGE INTENTIONALLY LEFT BLANK

## LOADING

Before each flight, insure that the total weight and the load balance are within the established limits. For this, use the weight and balance chart in section 6.

## NORMAL OPERATING SPEEDS

The speeds reminded here under are indicated air speeds recommended for normal operations.

They are based on a standard aircraft, operated at gross weight, in standard atmosphere, at sea level. They can change from one aircraft to another, depending on installed equipment, aircraft and engine condition, atmospheric conditions and pilot proficiency.

- Best rate of climb speed
  - flaps in take off position (1<sup>st</sup> notch) ..... (81 kt) 150 km/h
  - flaps up ..... (92 kt) 170 km/h
  
- Best angle of climb speed
  - flaps in take off position (1<sup>st</sup> notch) ..... (70 kt) 130 km/h
  - flaps up ..... (76 kt) 140 km/h
  
- Maximum operating speed in turbulence
  - flaps up ..... (140 kt) 260 km/h
  
- Maximum speed
  - flaps in landing position (2<sup>nd</sup> notch) ..... (92 kt) 170 km/h
  
- Landing speed final approach
  - flaps in landing position (2<sup>nd</sup> notch) ..... (68 kt) 125 km/h



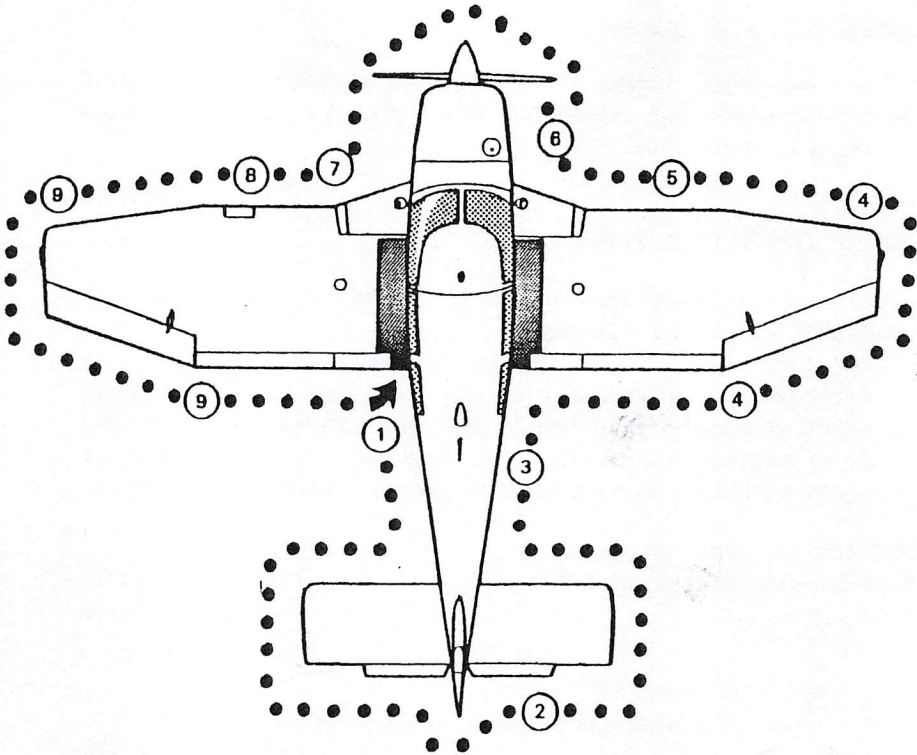

## PREFLIGHT INSPECTION

To be performed before each flight.

This inspection may be reduced after intermediate on route landings.

Magneto switch .....	off
Controls .....	free
Battery switch .....	on
Flaps .....	check operation
Fuel quantity .....	check
Battery switch .....	off
Aircraft documents .....	check availability on board
Baggage .....	check stowing

Check flight controls displacements, then make an aircraft walk-around inspection (as shown above) beginning at the fuselage left side.

- 
- 1 Fuel filler cap . . . . . in place, locked  
 Static vent . . . . . clean, unobstructed  
 Fuselage main tank drain valve . . . . . actuated  
 Baggage compartment door . . . . . tight fitted, closed and locked
- 
- 2 Horizontal stabilizer . . . surface condition, hinges without clearance  
 Rudder . . . . . check hinges and clearance
- 
- 3 Static vent . . . . . clean, unobstructed
- 
- 4 Flap and aileron . . . . . check condition and hinges  
 Wing tip and navigation light (optional) . . . . . check condition
- 
- 5 Stall warning . . . . . clean, check displacement  
 Right main landing gear . . . . . check attachment and fairing condition  
 . . . . . normal shock absorber compression  
 . . . . . tyre inflated  
 Right tank drain valve . . . . . actuated
- 
- 6 Fuel drain valve . . . . . actuated  
 Oil level . . . . . check, oil cap secured, panel closed  
 Engine cowl attachment . . . . . check  
 Propeller . . . . . clean, in good condition  
 Propeller spinner . . . . . no play  
 Air inlets . . . . . clean, unobstructed
- 
- 7 Nose gear . . . . . check attachment and fairing condition  
 . . . . . normal shock absorber compression  
 . . . . . tyre inflated  
 . . . . . tow-bar removed  
 Exhaust pipes . . . . . rigid  
 Canopy cleanliness . . . . . check
- 
- 8 Left main landing gear . . . . . check attachment and fairing condition  
 . . . . . normal shock absorber compression  
 . . . . . tyre inflated  
 Left tank drain valve . . . . . actuated  
 Pitot . . . . . clean, unobstructed  
 Lights (optional) . . . . . glass clean
- 
- 9 Wing tip and navigation light (optional) . . . . . check condition  
 Flap and aileron . . . . . check condition and hinges

## CABINE INTERIOR CHECK PRIOR START-UP

- Canopy ..... closed and locked
- Parking brake.....locked
- Front seats.....adjusted and locked
- Belts and harness ..... adjusted and fastened
- Flight controls free ..... without play or excessive friction  
..... (check rudder on taxi)
- Master switch..... on
- Elevator trim.....verify travel then bring to take-off position

## STARTING ENGINE

### Normal procedure

- Carburator heat ..... off
- Mixture ..... full rich
- Strobe light ..... on
- Gauges.....check
- Fuel valve..... check operation, open
- Magneto switch..... L
- Electric pump..... on
- Throttle ..... carry out 2 or 3 injections, then  $\frac{1}{4}$  travel forward
- Propeller area ..... clear
- Canopy ..... closed and locked
- Flaps ..... retracted
- Starter ..... on (max. operation time 15 to 20 sec)
- When engine fires magneto switch ..... L+R ("both")

### Hot engine procedure

Same as "normal procedure", but without injection.

### Cold weather procedure

Same as "normal procedure", but keeping successive injections up to 900 to 1000 rpm.



**Engine "flooded"**

- Electric pump ..... off
- Mixture..... cut-off
- Throttle ..... full power
- Starter ..... operate for several seconds

As soon as the engine starts, advance mixture control to "rich", and resume the normal procedure, without injection.

**CAUTION**

Avoid operating the starter for more than 20 seconds. Wait at least a minute before operating it again.

As soon as the engine is running, verify the engine oil pressure. If it is zero after 15 to 20 seconds, switch off, and investigate the cause.

**AFTER THE ENGINE STARTS**

- RPM..... 1200
- Electric pump ..... off
- Alternator switch..... on
- Voltmeter..... green arc
- Vacuum gauge (if installed) ..... check
- Lights..... test

- Radio ..... on
- Altimeter ..... set
- Flaps ..... up



**TAXIING**

- Parking brake ..... unlocked
- Brakes ..... test
- Turn and bank indicator ..... check
- Directional gyro ..... check setting
- Avoid exceeding 1200 rpm as long as oil temperature remains in the yellow range.

**ENGINE RUN-UP**

- Parking brake ..... locked
- Oil pressure and temperature ..... green range
- Fuel pressure ..... green range
- Mixture ..... fully rich
- Carburetor heat ..... off

**Magneto check**

Throttle ..... 2000 rpm

Magneto selection :

Max. drop between L or R and L+R ("Both") ..... 175 rpm

Max. difference between L and R ..... 50 rpm

**Carburetor heat check**

Carburetor heat ..... on  
Check rpm drop, (approx. 100) then return to ..... off

**Mixture check**

Lean until rpm reduction, then  
return to "full rich"

**Engine idle check**

Throttle ..... 600 to 650 rpm

**BEFORE TAKE OFF**

Controls ..... free  
 Magneto switch ..... L+R ("Both")  
 Cabin (Seats,belts,canopy) ..... check  
 Fuel ..... switch the most full tank  
 Electric pump ..... on  
 Elevator trim ..... neutral according to balance  
 Engine instruments ..... check  
 Flight Instruments ..... set  
 Flaps ..... fully down, then return to "take off position"  
 Throttle ..... "holding" 1200 rpm

**TAKE OFF**

**Normal take off**

Take off minimal rpm ..... 2200  
 Take off speed ..... (54 kt) 100 km/h  
 Initial climb speed ..... (70 kt) 130 km/h

After obstacle clearance,

reduce angle of climb to obtain ..... (81 kt) 150 km/h  
 Electric pump ..... off  
 Fuel pressure ..... check (green range)  
 Flaps ..... up

**Short take off**

Flaps ..... (1<sup>st</sup> notch) take off position  
 Apply full power (brakes applied) ..... (mini.) 2200 rpm  
 then release the brakes  
 Take off speed ..... (54 kt) 100 km/h  
 Then, if necessary, (to clear an obstacle)  
 best angle of climb speed ..... (70 kt) 130 km/h

**Cross wind take off**

Flaps ..... (1<sup>st</sup> notch) take off position

Ailerons ..... into the wind

Take off at a slightly higher airspeed than normal.

Correct drift in the normal way (max. bank angle, close to the ground: 15°)

Demonstrated cross-wind velocity (22 kt) 40 km/h

**CLIMB**

**Normal climb (flaps up)**

Set climb speed 170 km/h (92 kt); 160 km/h (86 kt) at ceiling.

Above 5000 ft, adjust mixture.

**Best angle of climb**

A better rate of climb is obtained at 130 km/h (70 kt), flaps in take off position (1<sup>st</sup> notch), and 140 km/h (76 kt) with flaps up.

**NOTE**

This type of climb should only be used exceptionally, due to poor engine cooling.

**CRUISE**

Refer to Section 5 for rpm settings and cruise performance.

### Operation of mixture control

Maintain mixture control in the "full rich" position during take off and in the climb.

In certain conditions (high altitude take off, long climb above 5000 ft, carburetor heat on), this setting could be too rich, and result in irregular engine operation or loss of power.

In these cases, adjust the mixture to recover regular engine operation, and not for fuel economy.

Mixture adjustment when in stable cruise:

Progressively lean the mixture until a slight reduction in rpm is noted: then lightly enrich to re-establish power and normal engine operation.

#### NOTE

Take care not to lean the mixture too much, which would cause engine overheating.

**ALWAYS ENRICH THE MIXTURE BEFORE AN INCREASE IN POWER.**

### USE OF FUEL

Switch on the electric pump when changing tank.

Switch the most full tank before take off or landing.



## DESCENT

### Rapid descent

Power ..... as required to maintain the desired descent path  
Carburetor heat as required ..... on or off  
Each 1500 ft, apply power to avoid excessive engine cooling, and to clean the spark plugs.

### Approach or down wind

Fuel ..... switch the most fuel tank  
Mixture ..... fully rich  
Electric pump ..... on  
Carburetor heat as required ..... on or off  
Cabin (Belts and seats) ..... check  
Flaps ..... below 170 km/h (92 kt) in take off position  
Speed ..... (81 kt) 150 km/h  
Elevator trim ..... set  
Roll stabilizer or Autopilot (if equipped) ..... off

### Final

Carburetor heat ..... off  
Flaps ..... below 150 km/h (81 kt) (2nd notch) landing position  
Approach speed ..... (68 kt) 125 km/h  
Elevator trim ..... set

## LANDING

### Short landing

Flaps ..... (2nd notch) landing position  
Approach speed, with throttle setting ..... (65 kt) 120 km/h  
After touchdown, brake heavily keeping nose up with elevator and retracting flaps.



### Landing in crosswind or gusty conditions

Flaps..... Take off position  
Approach speed ..... 130 km/h (70 kt) + 1/2 gust speed  
Correct drift in the normal way.  
Demonstrated crosswind ..... (22 kt) 40 km/h

### Overshoot procedure

Carburator heat off ..... check  
Throttle..... full  
Speed ..... (67 kt) 125 km/h  
Progressively raise flaps to the "take off position", then establish  
Normal climb speed .....(78 kt) 145 km/h

### AFTER LANDING

Electric pump ..... off  
Flaps..... up  
Navigation instruments ..... off

### ENGINE SHUT-DOWN

Parking brake .....tight  
Flaps..... down  
Radio and electrical equipment..... off  
Magneto cut-off check at idle .....off, then L + R ("Both")  
Rpm ..... 1000  
Mixture .....cut-off

### After the engine stops

Magneto switch ..... off  
Alternator switch..... off  
Battery switch..... off  
Release the parking brake when wheel chocks in place.

**PARKING BRAKE USE**

**Brake on**

Press on both pedals, keep pressure on, while pulling the parking brake control upwards.

Then release the pressure on the pedals (the parking brake control remains in the pulled position).

**Brake off**

Push the control down.

**EXTERNAL POWER SOCKET**

An external power socket without relay is installed to make easier the starting of the engine.

**Limitations:** not affected

**Emergency procedures:** not affected

**Normal procedures**

Battery switch	off
Alternator switch	off
External power socket	connected
Starter	engaged
After starting:	
Battery switch	on
Alternator switch	on
External power socket	disconnected

**NOTE :**

The external power source provides a 12 V tension as long as the battery switch is switched on.

TABLE OF CONTENTS

Noise limitation .....	5.02
Air speed installation calibration .....	5.02
Stall speeds .....	5.02
Take off performance .....	5.03
Climb performance .....	5.04
Cruise performance .....	5.06
Landing performance .....	5.07

## NOISE LIMITATION

In compliance with the decree of 19.02.1987, the maximum acceptable noise level for the DR400/180 aircraft, at a certified gross weight of (2425 lb) 1100 kg is 84.6 dB(A) (ICAO annex 16 chapter 10).

The noise level determined under the conditions of the decree, is 76.4 dB(A) at max. continuous power.

The DR400/180 aircraft has received noise limitation certificate nr N45.

## AIRSPPEED INSTALLATION CALIBRATION

**VC = (VI + calibration) is substantially equal to VI**

The above figures do not take into account the ASI own tolerance.

### NOTE

All speeds in this manual are Indicated Air speeds unless otherwise specified.

## STALL SPEEDS

Weight 1100 kg (2425 lb) engine idle	km/h (kt)		
	0°	30°	60°
Bank angle			
Flaps up	105 (57)	113 (61)	148 (78)
Flaps Take off position	99 (53)	106 (57)	140 (76)
Flaps Landing position	95 (51)	102 (55)	134 (72)



## TAKE OFF PERFORMANCE

At gross weight 1100 kg (2425 lb)

Without wind, flaps in "take off position" (1<sup>st</sup> notch), engine full power.

Take off speed.....(54 kt) 100 km/h

Over 15 m (50 ft) barrier speed.....(70 kt) 130 km/h

Pressure Altitude (ft)	Temperature °C (°F)	Weight 1100 Kg (2425 lb)				Weight 900 kg (1984 lb)			
		Take off distance		Run to clear 15m(50ft) barrier		Take off distance		Run to clear 15m(50ft) barrier	
		m	(ft)	m	(ft)	m	(ft)	m	(ft)
0	- 5 (23)	215	(700)	445	(1450)	120	(395)	250	(820)
	Std = 15 (59)	250	(815)	515	(1690)	140	(460)	290	(955)
	35 (95)	290	(945)	600	(1955)	165	(535)	340	(1105)
2500	- 10 (14)	260	(860)	540	(1780)	150	(485)	310	(1005)
	Std = 10 (50)	305	(1005)	635	(2085)	175	(565)	360	(1175)
	30 (86)	355	(1165)	735	(2415)	200	(655)	415	(1360)
5000	- 15 (5)	330	(1075)	680	(2225)	185	(605)	385	(1255)
	Std = 5 (41)	385	(1260)	795	(2610)	215	(710)	450	(1475)
	25 (77)	445	(1465)	925	(3035)	250	(825)	520	(1710)
8000	- 21 (-6)	430	(1410)	890	(2925)	245	(795)	505	(1660)
	Std = -1 (30)	505	(1660)	1050	(3445)	285	(940)	590	(1945)
	19 (66)	590	(1935)	1225	(4010)	335	(1095)	695	(2265)

Head wind influence: For 10 kt multiply by 0.85  
 For 20 kt multiply by 0.65  
 For 30 kt multiply by 0.55

Down wind influence: Add 10% to distance per section of 2 kt

Dried grass runway: Add 15%



## CLIMB PERFORMANCE

### 1) Flaps, take off position:

At maximum weight of 1100 kg (2425 lb) in standard atmosphere

Maximum rate of climb after take off ..... (827 ft/mn) 4.2 m/s  
reduction of 0.24 m/s (47 ft/mn) per 1000 ft  
Best rate of climb speed ..... (81 kt) 150 km/h  
Best angle of climb speed ..... (70 kt) 130 km/h

### 2) Flaps up:

In standard atmosphere,  
Full throttle, mixture best power,

- At maximum weight of 1100 kg (2425 lb):

Maximum rate of climb after take off ..... (885 ft/mn) 4.5 m/s  
reduction of 0.24 m/s (47 ft/mn) per 1000 ft  
Service ceiling ..... 14720 ft  
Best rate of climb speed after take off ..... (92 kt) 170 km/h  
up to ceiling (86 kt) 160 km/h  
Best angle of climb speed ..... (76 kt) 140 km/h

- At weight of 900 kg (1984 lb):

Maximum rate of climb after take off ..... (1200 ft/mn) 6.1 m/s  
reduction of 0.26 m/s (51 ft/mn) per 1000 ft  
Service ceiling ..... 19720 ft

### Temperature influence:

Each 10°C above standard, lowers the ceiling by 1000 ft and reduces rate of climb by 0.24 m/s (47 ft/mn).

**Time, Consumption, Climb distance**

At gross weight 1100 kg (2425 lb)  
 Without wind, in standard atmosphere,  
 Flaps retracted, full power: maximum rate of climb after take off.  
 Start and roll consumption included.

PRESSURE ALTITUDE ZP (ft)	TIME (min)	FUEL CONSUMPTION l (imp/us gal)	RANGE	
			(km)	(Nm)
3000	4	4.5 (1/1.2)	9.3	5
5500	7.5	8 (1.8/2.1)	17.6	9.5
8500	16.5	15 (3.3/4)	38.8	21

**Glide performance**

Engine off, the aircraft glides 9,3 time its height (without wind) at 150 km/h (81 kt).

Altitude and temperature do not have a perceptible influence.

**CRUISE PERFORMANCE**

At gross weight 1100 kg (2425 lb), in standard atmosphere.  
 Optimum mixture setting, usable fuel (41.58 imp/49.1 us gal ) 189 l.  
 Without reserve fuel, without wind.

Consumption and climbing time compensated with descent.

ALTI- TUDE  Zp(ft)	POWER		FUEL CONSUMPTION			TRUE AIR SPEED		ENDU- RANCE  h.min	RANGE	
	%	rpm	l/h	gal/h		km/h	kt		km	Nm
				imp	us					
0	75	2500	38	8.4	10.2	237	128	4.55	1178	636
	65	2350	33	7.3	8.8	220	119	5.40	1248	674
2500	75	2550	38	8.4	10.2	243	131	4.55	1208	652
	65	2400	33	7.3	8.8	225	121	5.40	1288	696
4500	75	2600	38	8.4	10.2	248	134	4.55	1233	666
	65	2450	33	7.3	8.8	230	124	5.40	1317	711
6500	75	2650	38	8.4	10.2	254	137	4.55	1263	682
	65	2500	33	7.3	8.8	235	127	5.40	1345	727
8500	75	2700	38	8.4	10.2	257	139	4.55	1278	690
	65	2550	33	7.3	8.8	240	130	5.40	1375	742
10500	65	2580	33	7.3	8.8	245	132	5.40	1402	757

**LANDING PERFORMANCE**

At gross weight 1045 kg (2304 lb),  
 Without wind, flaps in "landing" position, engine idling,  
 Dried and plane concrete runway,

Over 15 m (50 ft) barrier speed ..... (68 kt) 125 km/h  
 Touch down speed ..... (51 kt) 95 km/h

PRESSURE ALTITUDE  Zp (ft)	TEMPERATURE  °C (°F)	WEIGHT 1045 kg (2304 lb)				WEIGHT 845 kg (1863 lb)			
		Landing distance		Landing ground roll over 15m(50ft) barrier		Landing distance		Landing ground roll over 15m(50ft) barrier	
		m	(ft)	m	(ft)	m	(ft)	m	(ft)
0	- 5 (23)	230	(755)	500	(1641)	190	(623)	425	(1394)
	Std = 15 (59)	250	(820)	530	(1739)	200	(656)	450	(1476)
	35 (95)	270	(886)	560	(1837)	215	(705)	475	(1558)
4000	- 13 (7)	260	(853)	550	(1805)	210	(689)	465	(1526)
	Std = 7 (45)	280	(919)	585	(1919)	230	(755)	495	(1624)
	27 (81)	300	(984)	620	(2034)	240	(787)	520	(1706)
8000	- 21 (-6)	295	(968)	610	(2001)	240	(787)	510	(1673)
	Std = - 1 (30)	320	(1050)	650	(2133)	260	(853)	545	(1788)
	19 (66)	340	(1116)	690	(2264)	275	(902)	575	(1887)

Head wind influence: For 10 kt multiply by 0,85  
 For 20 kt multiply by 0,65  
 For 30 kt multiply by 0,55

Down wind influence: Add 10% to distance per section of 2 kt

Dried grass runway: Add 15%

PAGE INTENTIONALLY LEFT BLANK



**SECTION 6**

**WEIGHT AND BALANCE**

**TABLE OF CONTENTS**

Weight and balance diagram .....	6.02
Use of the weight and balance diagram .....	6.03

# FLIGHT MANUAL DR400/180

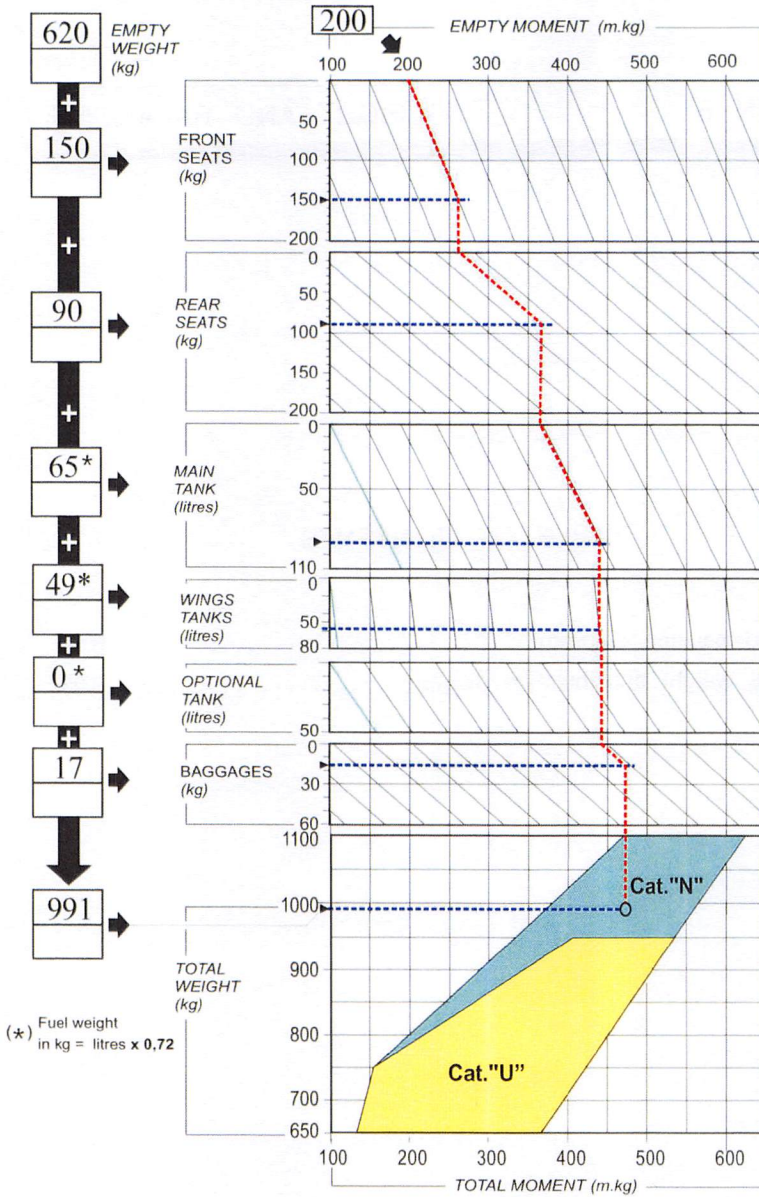

USE OF THE WEIGHT AND BALANCE DIAGRAM

- 1) Calculate the total loaded aircraft weight :  
 empty weight (from the weight and balance sheet)  
 + pilot and passengers  
 + baggage  
 + standard fuel

Insure that total weight does not exceed 1100 kg (2425 lb) in "N" category and 950 kg (2095 lb) in "U" category.

- 2) Place the empty aircraft moment (from the weight and balance sheet) on the upper scale of the opposite diagram, and follow the example indicated by the dashed line.

The resulting point must be within centre of gravity moment envelope (shaded area), for the load to be within limits.

**EXAMPLE \***

Empty aircraft - moment	.....	(1447 ft.lb)	200 m.kg
Empty aircraft - weight	.....	(1367 lb)	620 kg
Pilot + Front passenger	.....	(331 lb)	150 kg
Rear passengers	.....	(198 lb)	90 kg
Main fuel 90 l (24 imp/20 us gal)	.....	(143 lb)	65 kg
Wing fuel 68 l (15 imp/18 us gal)	.....	(108 lb)	49 kg
Baggage	.....	(37.5 lb)	17 kg
<b>TOTAL WEIGHT</b>	.....	<b>(2185 lb)</b>	<b>991 kg</b>

**CENTRE OF GRAVITY** : within the envelope

- 1 litre AVGAS = 0,72 kg (1.6 lb)
- 1 imp gal AVGAS = 3.27 kg (7.21 lb)
- 1 us gal AVGAS = 2.7 kg (6 lb)

**\* ATTENTION**

For your aircraft center of gravity calculation, please do not use values of empty aircraft weight and empty aircraft moment indicated in the above example. Use values indicated on the last weight and balance sheet of your aircraft.

PAGE INTENTIONALLY LEFT BLANK



**INVENTAIRE DES EQUIPEMENTS**  
EQUIPMENTS LIST

TYPE : **400/180**

IMMATRICULATION : **HB-KOE**  
REGISTRATION :

N° SERIE : **2569**  
SERIAL N° :

Classe	Qté	DESIGNATION	REFERENCE	FABRICANT	N° SERIE	X
Class	Qty	DESCRIPTION		MANUFACTURER	SERIAL N°	Ø
S	1	MOTEUR	O-360-A1P	TEXTRON-LYCOMING	L-39689-36A	X
S	1	BATI MOTEUR	51.26.10.000	APEX INDUSTRIES	04/0245203	X
S	1	ALTERNATEUR	LW-14371	KELLY	E041393	X
S	1	DEMARREUR	31A22470	ESI	E053693	X
S	1	MAGNETO GAUCHE	66GC25SFNN	SLICK	04031630	X
S	1	MAGNETO DROITE	66GP-OSANN	SLICK	04032553	X
S	1	CARBURATEUR	61C22551	PAM	75582305	X
S	1	SILENCIEUX ECHAPP. STD	51.36.30.110	APEX INDUSTRIES	043305 07	X
S	1	RADIATEUR HUILE	2002 A	N.D.M.	A04-2769-106	X
S	1	POMPE A VIDE	1U128-006	SIGMA TEK	T41241H	X
S	1	SONDE TEMPERAT. HUILE	53.21.16.000	APEX INDUSTRIES	Sans n°	X
S	1	TRANSMETTEUR P° HUILE	53.26.10.000	APEX INDUSTRIES	Sans n°	X
S	1	TRANSMETTEUR P° ESS.	52.18.00.010	APEX INDUSTRIES	Sans n°	X
S	1	HELICE	76EM8S5-0-64	SENSENICH	37135K	X
S	1	BATTERIE	532-11	PRESTOLITE	Sans n°	X
S	1	RELAJ BATTERIE	67.11.04.060	APEX INDUSTRIES	Sans n°	X
S	1	RELAJ DEMARREUR	69.11.12.050	APEX INDUSTRIES	Sans n°	X
S	2	CLES VERRIERE	Sans référence	CITROEN	C430	X
S	1	FUSELAGE	22,26,00,003	APEX INDUSTRIES	B 509	X
S	1	BATI ATTERRISSEUR AV.	42.12.02.000	APEX INDUSTRIES	0400542-04	X
S	1	ATTERRISSEUR AVANT	42.26.00.000	APEX INDUSTRIES	04005982181	X
S	1	RESERVOIR ESSENCE PPAL	52.18.42.100	APEX INDUSTRIES	04/0303302	X
S	1	JAUGE RESERVOIR PPAL	52.18.58.000	APEX INDUSTRIES	Sans n°	X
S	1	ROBINET ESSENCE PPAL	52;88;07;500	APEX INDUSTRIES	040364002	X
S	4	ROBINET DE PURGE	52.11.35.020	APEX INDUSTRIES	Sans n°	X
S	1	POMPE ELECTRIQUE	52.88.03.100	APEX INDUSTRIES	Sans n°	X
S	1	VALVE DE FREINS	75.26.05.020	APEX INDUSTRIES	Sans n°	X
S	1	MAITRE-CYLINDRE GAUCHE	75.18.50.030	APEX INDUSTRIES	Sans n°	X
S	1	MAITRE-CYLINDRE DROIT	75.18.50.010	APEX INDUSTRIES	Sans n°	X
S	4	CEINTURE AVEC PION	79.18.11.010	APEX INDUSTRIES	Sans n°	X
S	4	BRIN RETACTABLE	79.18.11.020	APEX INDUSTRIES	Sans n°	X
S	0	BRIN FIXE	79.18.11.040	APEX INDUSTRIES	Sans n°	X
S	1	GOVERNE DE PROFONDEUR	34,26,20,003	APEX INDUSTRIES	3221	X
S	2	VOLET TRIM DE PROFONDEUR	34,11,10,000	APEX INDUSTRIES	Sans n°	X
S	1	GOVERNE DE DIRECTION	32,26,00,003	APEX INDUSTRIES	2399	X
S	1	RESERVOIR AILE G. NM	52,18,20,020	APEX INDUSTRIES	040369601	X
S	1	RESERVOIR AILE D. NM	52,18,20,010	APEX INDUSTRIES	040154902	X
S	1	JAUGE RES. AILE G.	52,18,48,010	APEX INDUSTRIES	Sans n°	X
S	1	JAUGE RES. AILE D.	52,18,48,000	APEX INDUSTRIES	Sans n°	X
S	1	VOILURE	11,28,00,003	APEX INDUSTRIES	D 509	X
S	1	LONGERON	11,26,00,010	APEX INDUSTRIES	2404	X
S	1	ATTERRISSEUR GAUCHE	41.26.00.010	APEX INDUSTRIES	04008112095	X
S	1	ATTERRISSEUR DROIT	41.26.00.020	APEX INDUSTRIES	04005972099	X
S	2	ETRIER DE FREINS	41.23.02.000	APEX INDUSTRIES	Sans n°	X
S	1	AILERON GAUCHE	15,26,00,013	APEX INDUSTRIES	3425	X
S	1	AILERON DROIT	15,26,00,013	APEX INDUSTRIES	3425	X
S	1	VOLET GAUCHE	16,18,25,001+16,12,53,01	APEX INDUSTRIES	Sans n°	X
S	1	VOLET DROIT	16,18,25,002+16,12,53,02	APEX INDUSTRIES	Sans n°	X

A Darois, le:

29-juil-2004

APEX  
INDUSTRIES



## INVENTAIRE DES EQUIPEMENTS

Page 2/17

## EQUIPMENTS LIST

TYPE : 400/180

IMMATRICULATION : HB-KOE  
REGISTRATION :N° SERIE : 2569  
SERIAL N° :

Classe Class	Qté Qty	DESIGNATION DESCRIPTION	REFERENCE	FABRICANT MANUFACTURER	N° SERIE SERIAL N°	X Ø
S	1	SELECTEUR MAGNETOS	67.11.04.000	APEX INDUSTRIES	Sans n°	X
S	2	FUSIBLE 40A	69.22.15.000	APEX INDUSTRIES	Sans n°	X
S	1	AVERTISSEUR DECROCH.	69.11.03.110	APEX INDUSTRIES	Sans n°	X
S	1	INDICATEUR RESERV. 109L	76.26.12.000	APEX INDUSTRIES	Sans n°	X
S	1	INDICATEUR RESERV. G.	76.26.12.000	APEX INDUSTRIES	Sans n°	X
S	1	INDICATEUR RESERV. D.	76.26.12.000	APEX INDUSTRIES	Sans n°	X
S	1	INDICATEUR PRESS. ESS.	52,18,69,002	APEX INDUSTRIES	Sans n°	X
S	1	INDICAT. P° HUILE FAB.	76.20.50.000	APEX INDUSTRIES	Sans n°	X
S	1	INDICATEUR TEMP. HUILE	76.26.13.000	APEX INDUSTRIES	Sans n°	X
S	1	VOLTMETRE	76.33.53.000	APEX INDUSTRIES	Sans n°	X
S	1	BOUTON DEMARREUR	67.11.06.000	APEX INDUSTRIES	Sans n°	X
S	1	ALTIMETRE 1	5934-3	U.I.	438191	X
S	1	ANEMOMETRE	EA 5175	SIGMA TEK	T42452	X
S	2	CLES SELECTEUR MAGN.	Sans référence	TCM	PK 782	X
S	1	COMPAS MAGNETIQUE	C 2400	AIRPATH	AA721	X
O	1	EGT	211-100-0	ALCOR	252018	X
S	1	FEU DE NAVIGATION AR	01-0770034-02	WHELEN	Sans n°	X
S	1	FEU DE NAVIGATION D	W1250 PG-14	WHELEN	Sans n°	X
S	1	FEU DE NAVIGATION G	W1250 PR-14	WHELEN	Sans n°	X
S	1	FLASH / AMPOULE	64411-01	JPC	4512	X
S	1	HORAMETRE		<i>Winters</i>	Sans n°	X
S	1	HORIZON	23-501-06-22	SIGMA TEK	T78384N	X
S	1	MANO SUCTION	3-310-50	UMA	A 9738	X
O	1	O.A.T.	999-165-007	VDO	Sans n°	X
S	2	PHARE	4595	G.E.	Sans n°	X
S	1	REGULATEUR TENSION	614 17 00 B	J.P.C.	3113	X
S	1	SONDE DECROCHAGE	79.88.00.000	APEX INDUSTRIES	Sans n°	X
S	1	TACHYMETRE	D1-112-5025	MITCHELL	13928	X
S	1	TURN COORDINATOR	6407-14	S-TEC	9578	X
S	1	VARIOMETRE	7000C26	U.I.	307011	X
O	1	PRISE 12 v	66,00,00,000	APEX INDUSTRIES	Sans n°	X
O	1	PITOT CHAUFFANT	40,00,00,000	APEX INDUSTRIES	Sans n°	X

A Darois, le:

29 juillet 2004

APEX  
INDUSTRIES

**INVENTAIRE DES EQUIPEMENTS**  
EQUIPMENTS LIST

Page 3/17

TYPE : **400/180**

IMMATRICULATION : **HB-KOE**  
REGISTRATION :

N° SERIE : **2569**  
SERIAL N° :

Classe Class	Qté Qty	DESIGNATION DESCRIPTION	FABRICANT MANUFACTURER	REFERENCE	N° SERIE SERIAL N°	X Ø
S	1	HAUT PARLEUR	46C1FR	QUAM	Sans n°	X
S	1	MICROMAIN	100TRA	TELEX	Sans n°	X
S	1	COM / NAV / GLIDE 1	<del>KX 155-42</del> <i>ANC 255A</i>	<del>KING</del> <i>Garmin</i>	<del>38117</del>	X <small>AVIONTEC AG CH.145.0181</small>
S	1	IND NAV ILS 1	KI 204	KING	55959	X
O	1	COM / NAV 2	KX 125	KING	9839	X
S	1	GPS 1	KMD 150	KING	27102128	X
S	1	ATC	<del>KT 76C-00</del> <i>GTX 328</i>	<del>KING</del> <i>Garmin</i>	<del>17200</del>	X <small>AVIONTEC AG CH.145.0181</small>
S	1	ALTICODEUR	A 30.8	ACK	<del>85993</del> <i>113035</i>	X
O	1	AUDIO / IC / MARKERS	GMA 340	GARMIN	96269825	X
S	1	ANTENNE GPS	GA 56	GARMIN	520410	X
S	1	ELT	<del>E-04</del> <i>ME 406</i>	<del>ACK</del> <i>Artex</i>	<del>39472</del>	X <small>AVIONTEC AG CH.145.0181</small>
A Darois, le: 29 juillet 2004				APEX INDUSTRIES 		







# Apex Robin DR400/180 AFM Equipment List



Avionitec AG, General Aviation Center, P.O.BOX 63, CH-8058 Zürich-Airport, Phone : +41 43 816 44 39, FAX + 41 44 814 33 42, E-Mail : avionik@avionitec.ch, CH 145.0181

Registration Type	HB-KOE Robin DR400/180	Workorder Serial Nr.	7538 2569
-------------------	---------------------------	----------------------	--------------

LIST OF INSTALLED UNITS on 17. June 2016 :

AVIONITEC  
CH.145.018

Manufacturer	Unit Function	Unit Name	P/N	Weight ( kg )	Arm ( m )	Moment ( m kg )
PowerFLARM	Traffic Transceiver	PowerFLARM Core	FLAPFC11E	0.27	-0.20	-0.05
Aboba	FLARM Traffic Display	V4+M		0.11	-0.10	-0.01
Comant	ADS-B Antenna	CI-105	CI105-16	0.14	1.65	0.23
RAMI	FLARM Bottom Antenna	AV-75		0.18	0.35	0.06
RAMI	FLARM Top Antenna	AV-75(F)		0.18	3.82	0.69
Total installed Units				<b>0.88</b>	<b>1.04</b>	<b>0.92</b>

LIST OF INSTALLED UNITS on 19. May 2017 :

AVIONITEC AG  
CH.145.018

Manufacturer	Unit Function	Unit Name	P/N	Weight ( kg )	Arm ( m )	Moment ( m kg )
Garmin	NAV/COM	GNC 255A	011-02806-00	2.00	-0.25	-0.50
Total installed Units				<b>2.00</b>	<b>-0.25</b>	<b>-0.50</b>

WEIGHT AND BALANCE SUMMARY :

Running basic empty weight	<b>634.18</b>	<b>0.37</b>	<b>235.63</b>
Removed weight	<b>0.00</b>	<b>0.00</b>	<b>0.00</b>
Installed weight	<b>0.88</b>	<b>1.04</b>	<b>0.92</b>
N E W Running basic empty weight	<b>633.78</b>	<b>0.37</b>	<b>235.73</b>

Aircraft type: DR-400/180	Registration: HB-KOE	Serial number: 2569
---------------------------	----------------------	---------------------

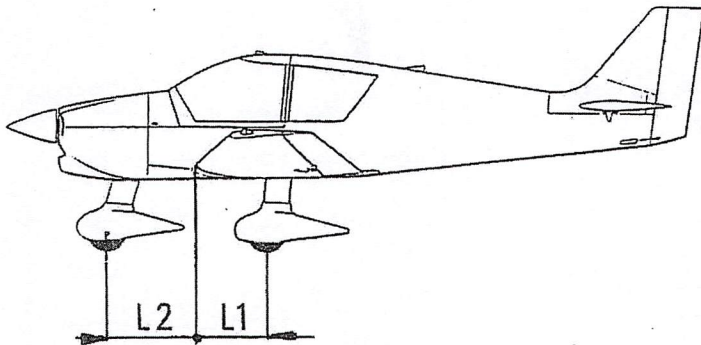

L1=0,828  
L2= 0,819

**AIRCRAFT WEIGHING ON WHEELS**

- Vertical moment datum: leading edge of the rectangular part of the wing
- Datum chord: 1.71 m
- Horizontal levelling: upper longeron (arm rests)

BASIC EMPTY WEIGHT					
	WEIGHT MEASURED		TARE		NET WEIGHT
	in kg		in kg		in kg
NOSE WHEEL	194,25	-	—	=	194,25
L/H MAIN WHEEL	222,75	-	—	=	222,75
R/H MAIN WHEEL	223,75	-	—	=	223,75
<b>TOTAL EMPTY WEIGHT =</b>					<b>640,75</b>
EMPTY MOMENT = SUM OF MOMENTS ABOUT EACH WHEEL					
	NET WEIGHT		MOMENT ARM		MOMENT
	in kg		in m		in m.kg
R/H WHEEL	223,75	x	0.828	=	185,27
L/H WHEEL	222,75	x	0.828	=	184,44
UNUSABLE FUEL*	—	x	1.120	=	—
NOSE WHEEL	194,25	x	-0.819	=	-159,10
<b>EMPTY MOMENT =</b>					<b>210,61</b>

\* Unusable fuel in main tank: 7.3 kg or 0.7 kg depending on model

W/O: 16-160 vom 1015/16



FIG. 3.1 - WEIGHING, BASIC EMPTY WEIGHT, EMPTY MOMENT





HB- **KOE** Muster Type **DR 400/180** Ort und Datum / Lieu et date **Birrfeld, 12.11.2010**

Bezugsebene gemäss Geräte-Kennblatt / Plan de référence selon la fiche de navigabilité **Leading edge of the rectangular of the wing**

Horizontallage gemäss Geräte-Kennblatt / Référence horizontale selon la fiche de navigabilité **Upper Longeron (arm rests)**

Grund der Wägung / Raison de la pesée **Alle 5 Jahre gemäss MM**

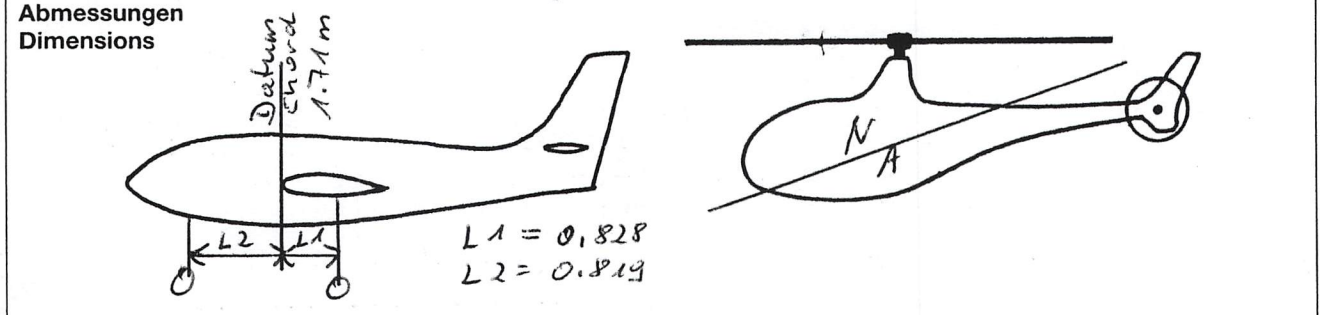

Alle Masse sowie Bezugsebene in die Figur eintragen / Reporter le plan de référence et les cotes des points de pesée sur le croquis approprié

**Wägung / Pesée** mit Ausrüstung gemäss Ausrüstungsliste des Luftfahrzeug-Flughandbuchs (AFM) / avec l'équipement installé selon la liste du manuel de vol de l'aéronef (AFM)

Verwendete Wagen / Balances utilisées	Hersteller / Constructeur	Werknummer / No. de série	Eichdatum / Date de calibr.
Links / A gauche	<b>A Evergreen</b>	<b>1778</b>	<b>27.4.09</b>
Rechts / A droite	<b>Evergreen</b>	<b>1777</b>	<b>27.4.09</b>
Vorne/Hinten / En avant/En arrière	<b>Evergreen</b>	<b>22173</b>	<b>27.4.09</b>

Wägung Nr. / Pesée no.	Wägepunkt / Point de pesée	Masse brutto / Masse brute kg	Tara / Tare	Masse netto / Masse net
<b>1</b>	Links / A gauche	<b>222</b>		
	Rechts / A droite	<b>214</b>		
	Vorne/Hinten / En avant/En arrière	<b>194</b>		
	Total	<b>630</b>		

<b>2</b>	Links / A gauche	<b>220</b>		
	Rechts / A droite	<b>212</b>		
	Vorne/Hinten / En avant/En arrière	<b>198</b>		
	Total	<b>630</b>		

**Hinweis / Note**

Ist die Abweichung in den Ergebnissen 1 und 2 grösser als 1%, ist eine 3. Wägung durchzuführen. / Au cas où la différence entre les résultats 1 et 2 est supérieure à 1%, effectuer une 3ème pesée.

Wägung Nr. / Pesée no.	Wägepunkt / Point de pesée	Masse brutto / Masse brute kg	Tara / Tare	Masse netto / Masse net
<b>3</b>	Links / A gauche	<b>224</b>		
	Rechts / A droite	<b>216</b>		
	Vorne/Hinten / En avant/En arrière	<b>193</b>		
	Total	<b>633</b>		

**Schwerpunktbestimmung / Détermination du centrage**

Durchschnittswerte aus den Wägungen / Valeurs moyennes des pesées	Masse kg	Arm/Bras m	Moment kg m
Wägepunkt links / Point de pesée gauche	<b>222</b>	<b>0.828</b>	<b>183.816</b>
Wägepunkt rechts / Point de pesée droit	<b>214</b>	<b>0.828</b>	<b>177.192</b>
Wägepunkt vorn/hinten / Point de pesée AV/AR	<b>195</b>	<b>-0.819</b>	<b>-159.705</b>
Für die Auswertung massgebend / Valeurs à utiliser pour le dépouillement	<b>631</b>	<b>0.319</b>	<b>201.303</b>

Übertragen auf Blatt 2 / A reporter sur la feuille 2

Verteilung: BAZL/OFAC weiss/blanc  
Distribution: Halter/Expl. gelb/jaune  
Insp. rosa/rosé

Gewogen durch: **H-BJR**  
Pesée effectuée par:

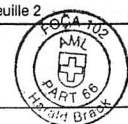



**Auswertung der Wägung (Motorflugzeuge und Helikopter)**  
**Dépouillement de la pesée (Avions à moteur et hélicoptères)**

**Tabelle I** Gewogene, aber nicht zur Leermasse gehörende Teile  
Equipements pesés, mais ne faisant pas partie de la masse à vide

Bezeichnung / Désignation	Masse	Arm/Bras	Moment
Total Abzüge / Total à retrancher			

**Tabelle II** Nicht gewogene, aber zur Leermasse gehörende Teile  
Equipements non pesés, mais faisant partie de la masse à vide

Bezeichnung / Désignation	Masse	Arm/Bras	Moment
Total Zuschläge / Total à ajouter			

**Leermasse** (Gemäss Definition des Luftfahrzeug-Flughandbuchs)  
**Masse à vide** (Selon définition du Manuel de Vol de l'aéronef)

	Masse <i>kg</i>	Arm/Bras <i>m</i>	Moment <i>kgm</i>
Übertrag Blatt 1: / Report feuille 1:	631	0,319	201,303
Öl <i>inkl.</i> / Huile SG:			
Nicht verwendbarer Treibstoff <i>inkl.</i> / Essence non-consommable SG:			
Nicht verwendbarer Treibstoff / Essence non-consommable SG:			
Abzüge gemäss Tabelle I / A retrancher selon table I			
Zuschläge gemäss Tabelle II / A ajouter selon table II			
Leermasse / Masse à vide	631	0,319	201,303

Resultat zu übertragen in AFM Deckblatt B  
Résultat à reporter à la page de garde B AFM

**Schwerpunktlage leer / Centrage à vide** (falls vorgeschrieben / si prescrit)

Leermasse-Schwerpunktbereich gemäss Gerätekenblatt bei \_\_\_\_\_ von \_\_\_\_\_ bis \_\_\_\_\_  
à \_\_\_\_\_ kg/lbs de \_\_\_\_\_ m/in à \_\_\_\_\_ m/in

Anmerkung: Der Schwerpunktbereich leer muss eingehalten werden, andernfalls ist das Luftfahrzeug durch Zugabe oder Entfernen von Ballast auszutrimmen.  
Note: Le domaine de centrage à vide doit être respecté, sinon l'aéronef doit être équilibré en ajoutant ou retranchant du lest.

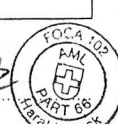
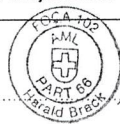



# Apex DR400/180 AFM Equipment List



Avionitec AG, General Aviation Center, P.O.BOX 63, CH-8058 Zürich-Airport, Phone : +41 43 816 44 39, FAX + 41 44 814 33 42, E-Mail : avionik@avionitec.ch, CH 145.0181

Registration Type	HB-KOE Robin DR 400/180	Workorder Serial Nr.	P191192 2569
----------------------	----------------------------	-------------------------	-----------------

LIST OF INSTALLED UNITS on 08. May 2009 :

AVIONITEC AG  
CH.145.0181

Manufacturer	Unit Function	Unit Name	P/N	Weight ( kg )	Arm ( m )	Moment ( m kg )
Artex	ELT System	ME 406	455-6605	2.10	3.90	8.19
Total installed Units				2.10	3.90	8.19

WEIGHT AND BALANCE SUMMARY :

Running basic empty weight	629.22	0.328	206.29
Removed weight	3.40	3.90	13.26
Installed weight	2.10	3.90	8.19
N E W Running basic empty weight	627.92	0.320	201.22

# Apex DR400/180 AFM Equipment List



Avionitec AG, General Aviation Center, P.O.BOX 63, CH-8058 Zürich-Airport, Phone : +41 43 816 44 39, FAX + 41 44 814 33 42, E-Mail : avionik@avionitec.ch, CH 145.0181

Registration Type	HB-KOE Apex DR 400/180	Workorder Serial Nr.	PI81069 2569
----------------------	---------------------------	-------------------------	-----------------

LIST OF INSTALLED UNITS on 14. Jan. 2009 :  CH.145.0181

Manufacturer	Unit Function	Unit Name	P/N	Weight ( kg )	Arm ( m )	Moment ( m kg )
Garmin	Mode S XPDR	GTX 328	011-01684-00	2.10	-0.15	-0.32
Total installed Units				<b>2.10</b>	<b>-0.15</b>	<b>-0.32</b>

## WEIGHT AND BALANCE SUMMARY :

Running basic empty weight	<b>628.72</b>	<b>0.328</b>	<b>206.21</b>
Removed weight	<b>1.60</b>	<b>0.15</b>	<b>0.24</b>
Installed weight	<b>2.10</b>	<b>0.15</b>	<b>0.32</b>
<b>N E W</b> Running basic empty weight	<b>629.22</b>	<b>0.328</b>	<b>206.29</b>

WEIGHT AND BALANCE DATA

TYPE: Type :	<b>DR 400/180</b>	N° DE SERIE : Serial n° :	<b>2569</b>	IMMATRICULATION: Registration :	<b>HB-KOE</b>
-----------------	-------------------	------------------------------	-------------	------------------------------------	---------------

DOMAINE DE MASSE ET CENTRAGE

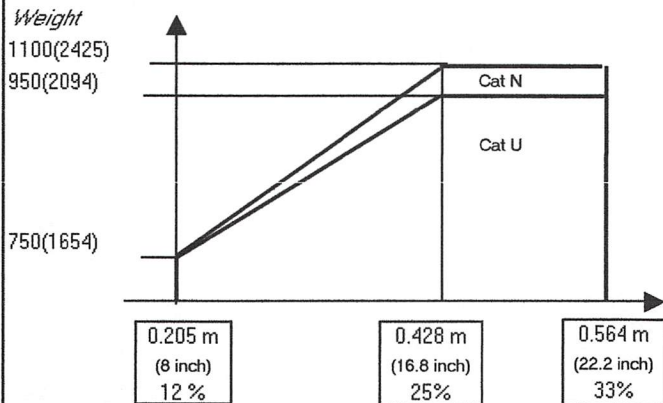

Référence verticale: Bord d'attaque de la partie rectangulaire de la voilure  
 Mise a niveau: Longeron de fuselage horizontal  
 C/G datum : leading edge of rectangular wing part  
 Levelling : horizontal reference top fuselage spar

Conditions de la pesée:  
 - plein d'huile  
 - équipements figurants au Registre de Contrôle  
 - essence non utilisable comprise dans la masse à vide  
 Weighing conditions :  
 - full operating oil  
 - equipment listed in the inspection report  
 - unusable fuel included in empty weight

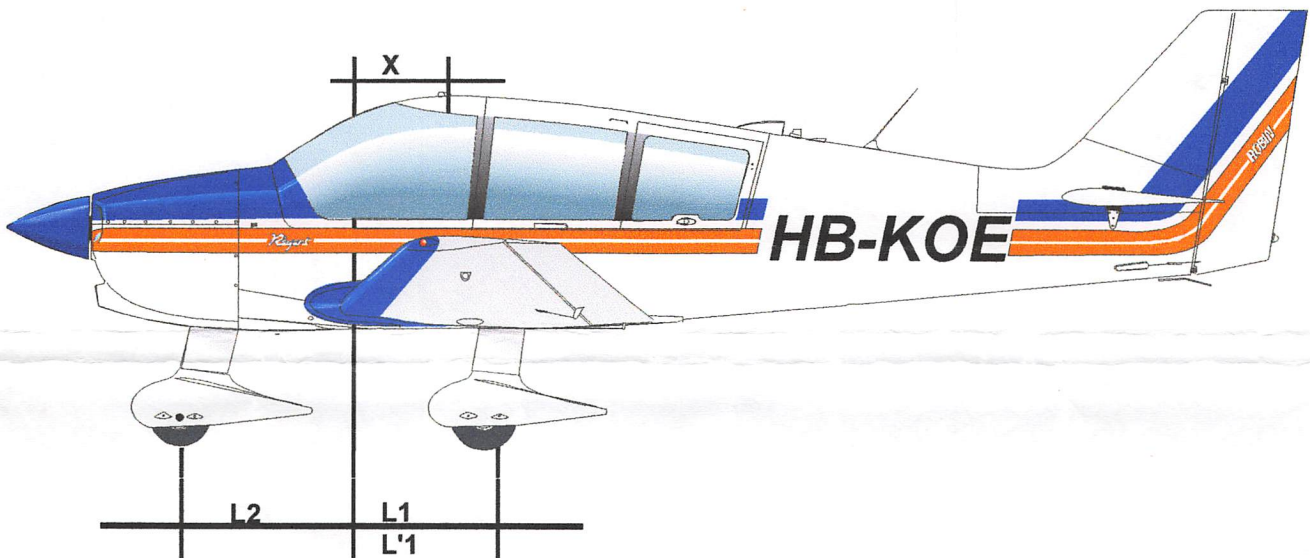

Corde de référence: 1,71 m (c.a.m)  
 Reference chord: 1,71 m (m.a.c)

MASSE ET CENTRAGE A VIDE  
 Weight and balance-Empty aircraft

		Masse(kg) Weight (Kg)	Bras de Levier(m) Lever arm (m)	Moment(m*kg) Moment(m*Kg)
ROUE PPALE D Main R wheel	L1	220	0,828	182,160
ROUE PPALE G Main L wheel	L'1	217	0,828	179,676
ROUE AV Front wheel	L2	191	0,819	-156,429
Essence non utilisable Unusable fuel		0,72	1,120	0,806
Avion vide Empty aircraft		628,72	0,328	206,213
<b>CENTRAGE Balance</b>		<b>19,18%</b>	c.a.m m.a.c	

A Darois, le: 15 mars 2005

Contrôle: APEX INDUSTRIES



PROCES VERBAL DE PESEE ET DE CENTRAGE

WEIGHT AND BALANCE DATA

TYPE: Type :	<b>DR 400/180</b>	N° DE SERIE : Serial n° :	<b>2569</b>	IMMATRICULATION: Registration :	<b>HB-KOE</b>
-----------------	-------------------	------------------------------	-------------	------------------------------------	---------------

DOMAINE DE MASSE ET CENTRAGE

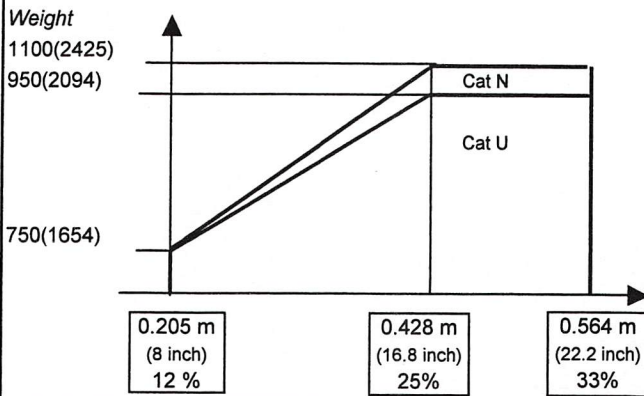

Référence verticale: Bord d'attaque de la partie rectangulaire de la voilure  
 Mise a niveau: Longeron de fuselage horizontal  
 C G datum : leading edge of rectangular wing part  
 Levelling : horizontal reference top fuselage spar

- Conditions de la pesée:
- plein d'huile
  - équipements figurants au Registre de Contrôle
  - essence non utilisable comprise dans la masse à vide
- Weighing conditions :
- full operating oil
  - equipment listed in the inspection report
  - unusable fuel included in empty weight

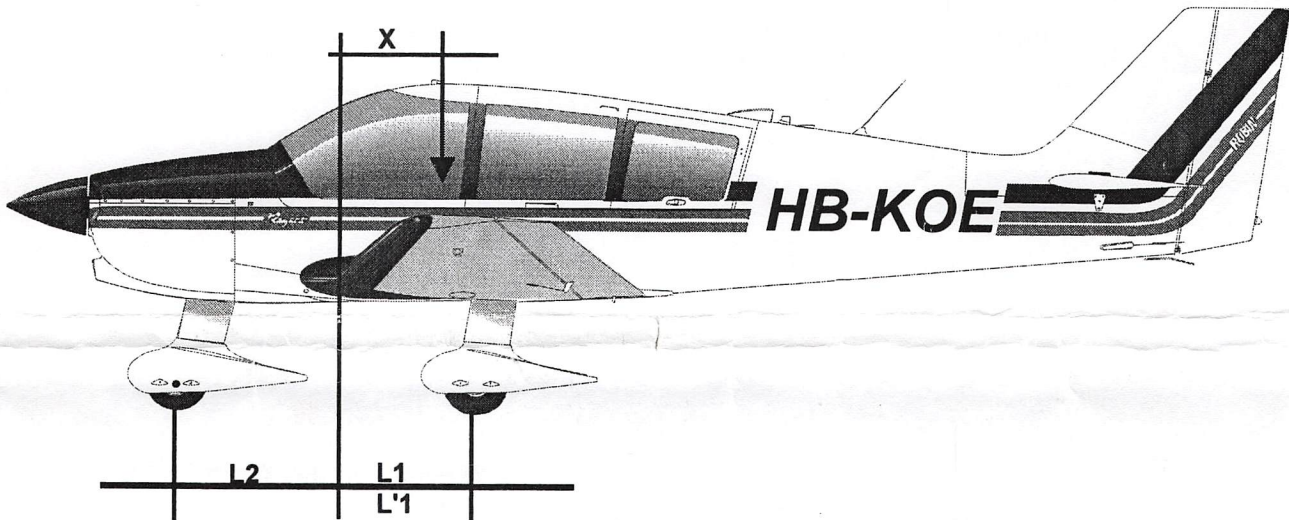

Corde de référence: 1,71 m (c.a.m)  
 Reference chord: 1,71 m (m.a.c)

MASSE ET CENTRAGE A VIDE  
 Weight and balance-Empty aircraft

		Masse(kg) Weight (Kg)	Bras de Levier(m) Lever arm (m)	Moment(m*kg) Moment(m*Kg)
ROUE PPALE D Main R wheel	L1	222	0,828	183,816
ROUE PPALE G Main L wheel	L'1	222,5	0,828	184,23
ROUE AV Front wheel	L2	187	0,819	-153,153
Essence non utilisable Unusable fuel		0,72	1,12	0,8064
Avion vide Empty aircraft		<b>632,22</b>	0,341177755	215,6994
<b>CENTRAGE</b> Balance		<b>19,95%</b>	c.a.m      m.a.c	

A Darois, le: 29-juil-2004

*ersucht März 2005*

APEX INDUSTRIES



TABLE OF CONTENTS

Supplement 1: Auxiliary fuel tank.....	7.03
Supplement 2 withdrawn.....	Pages 7.07 to 7.12 withdrawn
Supplement 3: Towing procedures .....	7.13
Supplement 4: Low voltage.....	7.19
Supplement 5: GPS .....	7.21
Supplement 6: S-TEC System 55 autopilot.....	7.26
Supplement 7: Sensenich 76EM8S5-0-58 propeller .....	7.45
Supplement 8: IFR .....	7.49

Page intentionally left blank

TABLE OF CONTENTS

Section 1 Description .....	7.04
Section 2 Limitations .....	7.05
Section 3 Emergency procedures .....	7.05
Section 4 Normal procedures .....	7.05
Section 5 Performance .....	7.05

**SECTION 1 - DESCRIPTION**

The auxiliary fuel tank is located on the bottom of the baggage compartment and is connected to the main fuel tank by a transfer line. Use first a sufficient quantity from the main fuel tank then refuel by pulling the auxiliary tank transfer valve control.

The quantity of auxiliary tank fuel is given by an independent gauge.

capacity ..... (11 imp/13,2 us gal) 50 l  
level arm ..... (63 in) 1,61 m

**NOTA**

The main fuel tank must be empty enough to receive fuel quantity from the auxiliary fuel tank.

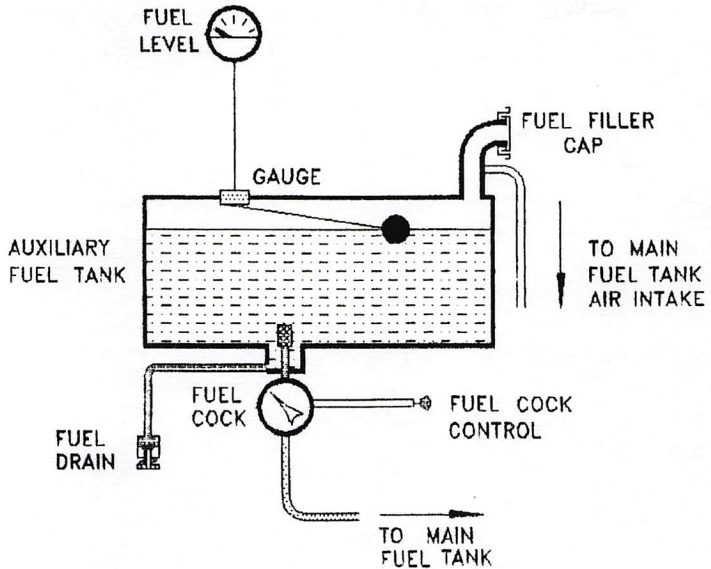



## SECTION 2 - LIMITATIONS

The maximum take off weight and the weight and balance limits are not modified by the installation of the auxiliary fuel tank. Therefore, limitations of Section 2 are not modified, except following placards which complete those of the pages 2.08, 2.09 and 2.10.

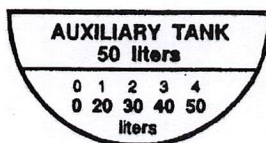
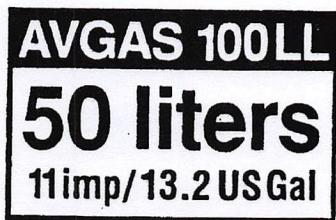

## SECTION 3 - EMERGENCY PROCEDURES

Emergency procedures are not affected by the installation of auxiliary fuel tank.

## SECTION 4 - NORMAL PROCEDURES

In addition to normal procedures actuate the auxiliary fuel tank drain valve during the pre-flight check (point 1 page 4.05).

## SECTION 5 - PERFORMANCE

Performance are not affected by the installation of auxiliary fuel tank because the maximum take off weight and the weight and balance limits are not modified.

PAGE INTENTIONALLY LEFT BLANK

*DR400/180 FLIGHT MANUAL*

---

Pages 7.07 to 7.12 are withdrawn.

Page intentionally left blank



TABLE OF CONTENTS

Section 1 Description .....	7.14
Section 2 Propellers approved for towing .....	7.14
Section 3 Glider towing procedures .....	7.14
Section 4 Banner towing procedures .....	7.15
Section 5 Limitations .....	7.16
Section 6 Performance .....	7.17

## SECTION 1 - DESCRIPTION

Your DR400/180 is equipped with:

- a structural reinforcement installed on the aircraft at the production stage
- a tube support bearing a AERAZUR or TOST tow-hook
- a hook-release handle near the pilot's seat
- an instruction placard near the hook-release handle.

## SECTION 2 - PROPELLERS APPROVED FOR TOWING

Gliders: 76-58, 76-54

(76-64 would enter the critical RPM - zone under normal utilisation)

Banners: 76-54

(76-58 would enter the critical RPM - zone under normal utilisation).

Propeller HO-27-HM-180/138 (gliders and banners)

## SECTION 3 - GLIDER TOWING PROCEDURES

In addition to the usual procedures, check the correct working of the hooks on the aircraft and on the glider.

### Towing configuration

First stage of flaps up to Vi ..... 140 km/h (76 kt)  
Then flaps ..... up position  
Full throttle whilst climbing

### Descent

Do not close throttle below 2500 rpm in order to avoid the engine cooling being too quick.

Recommended speed Vi ..... 250 km/h (135 kt)

## TOWING SPEED

### Gliders

Any speed is possible between the minimum aircraft towing speed  $V_r$  and the maximum authorised speed of the glider on tow.

The optimum climbing speed depends on characteristics of the glider: for gliders with a low wing loading and a medium glide ratio, the optimum speed is  $V_r$  where as it may exceed 130 km/h (70 kt) for gliders with a high wing loading and glide ratio.

A climbing speed higher than the optimum may be necessary in case of critical engine cooling.

## SECTION 4 - BANNER TOWING PROCEDURES

In addition to the usual procedures:

- Check the correct working of the hook on the aircraft.
- Then attach the cable to the aircraft and to the banner.
- Lay the folded banner on the ground in front of the aircraft at such a distance that it has reached a sufficient speed when lifting the banner. For a pick up hooking in flight, the approach speed of the aircraft should be 105 km/h (56 kt).

A speed very close to  $V_b$  should be maintained for the whole flight.

For banner towing at a slow speed and under hot weather conditions, it is advised if need be to install the cooling flap on the inferior engine cowling to obtain a better engine cooling. This flap belongs to the optional equipment of the aircraft.

Following instruction placard is mandatory on this aircraft when equipped with a tow-hook:

**SEE APPROVED FLIGHT MANUAL FOR TOWING INSTRUCTIONS**

**SECTION 5 - LIMITATIONS**

See notes	1)	2)	3)
Weight of the towing aircraft kg	760	850	1000
Minimum glider towing speed Vr km/h	115	120	130
Minimum banner towing speed Vb km/h	100	105	120
Minimum authorized speed for the glide glider on tow km/h	140	145	160
Maximum glider weight for Vz = 0.7 m/s	915	710	370
Maximum glider weight for Vz = 1.7 m/s	710	555	295
100Cx.S maximum of the banner	190	125	45

- Notes:
- 1) Normal utilisation: 1 pilot, 110 l fuel
  - 2) Case of towing pilot's schooling
  - 3) Exceptional case: Passengers transport with a light on tow or leaflets dropping with a reduced banner.

Following placards complete those of the pages 2.08, 2.09 and 2.10:

**TOWING HOOK**  
(PULL TO RELEASE)

**FOR TOWING INSTRUCTIONS**  
**SEE APPROVED FLIGHT MANUAL**

**BAGGAGE BAY MAX. LOAD**  
**60 kg**  
**SEE LOADING DIAGRAM**

**BREAKING RESISTANCE OF THE TOWING CABLE**

Maximum .....1000 daN  
Minimum .....0,8 times the weight of the glider



**SECTION 6 - TOWING PERFORMANCE**

Weight of the towing aircraft (kg)	760	850	1000
Stalling speed (Vo) with first stage of flaps (km/h)	87	92	100
Climbing speed at Vr at ground level with a glider under extreme conditions (conditions FAR 23.65b) m/s	2,75	2,9	3,15
At Vr without glider (m/s)	7,2	6,2	4,9
At Vb with extreme banner	2,75	2,9	3,15
At Vb without banner	6,3	5,4	4,4

**TAKE OFF PERFORMANCE ON GRASS RUNWAY WITH A GLIDER  
EQUIPPED WITH A WHEEL**

**Weight of towing aircraft: 760 kg**

Weight of glider		300 kg		600 kg	
Altitude	Temperature	Take off distance	Run to clear	Take off distance	Run to clear
Z: 0	St: 15°	410 m	225 m	580 m	330 m
	St: +20°	455 m	255 m	650 m	375 m
Z: 4000 ft	St: 7°	555 m	320 m	810 m	480 m
	St: +20°	620 m	360 m	910 m	550 m

**Weight of towing aircraft: 850 kg**

Weight of glider		300 kg		600 kg	
Altitude	Temperature	Take off distance	Run to clear	Take off distance	Run to clear
Z: 0	St: 15°	505 m	285 m	710 m	415 m
	St: +20°	560 m	325 m	795 m	470 m
Z: 4000 ft	St: 7°	695 m	410 m	1005 m	615 m
	St: +20°	775 m	465 m	1135 m	705 m

**Weight of towing aircraft: 1000 kg**

Altitude	Temperature	Take off distance	Run to clear
Z: 0	St: 15°	700 m	415 m
	St: +20°	780 m	470 m
Z: 4000 ft	St: 7°	985 m	600 m
	St: +20°	1110 m	690 m

SUPPLEMENT 4

LOW VOLTAGE

A steady warning light is installed which will illuminate if the alternator output reduces to a level where the battery supplies power to the bus-bar (See Airworthiness Notice n°88).

**Before engine start**

Check low volts warning..... ON

**After engine start**

Check low volts warning..... OFF

**If warning illuminates during flight**

Reduce electrical load

Battery duration approx..... 30 minutes

Land on the nearest suitable airfield.

**NOTE**

Warning may illuminate with low engine rpm. Check it goes without when rpm increases.

PAGE INTENTIONALLY LEFT BLANK



## TABLE OF CONTENTS

Section 1 General.....	7.22
Section 2 Limitations.....	7.22
Section 3 Emergency procedures .....	7.22
Section 4 Normal procedures.....	7.22
Section 5 Performances.....	7.23
Section 6 Weight and balance.....	7.23

## SECTION 1 - GENERAL

The GPS mentioned hereunder are approved on DR400 series for day VFR in view of the ground or the sea.

The integrity of the position indicated by the GPS is not guaranteed. It is therefore the responsibility of the pilot to verify the accuracy of this position by all means of navigation available.

The GPS operating manual at latest edition must be on board.

The coupling of the GPS mentioned hereunder to a flight director or to an autopilot is not authorised ( except for the GPS underlined hereunder ).

GARMIN	100 AVD, 150, 150 XL, GNC 250 XL, GNS 430
KING	<u>KLN89</u> , <u>KLN89B</u> , KLN 90, <u>KLN 90A</u> <u>KLN 90B</u> , KLX135, KLX135A
MAGELLAN	SKY NAV 5000
TRIMBLE	TNL 2000

## SECTION 2 - LIMITATIONS

The following placard complements those described on page 2.08

GPS LIMITED TO DAY VFR IN VIEW OF THE GROUND OR THE SEA ONLY
---

## SECTION 3 - EMERGENCY PROCEDURES

Not affected

## SECTION 4 - NORMAL PROCEDURES

Not affected

**SECTION 5 - PERFORMANCES**

Not affected

**SECTION 6 - WEIGHT AND BALANCE**

Not affected





## TABLE OF CONTENTS

Section 1	Description.....	7.26
Section 2	Limitations.....	7.27
Section 3	Emergency procedures.....	7.28
Section 4	Normal procedures.....	7.30
Section 5	Performance.....	7.43
Section 6	Weight and balance.....	7.43

**SECTION 1 - DESCRIPTION**

The 2 axes S-T4C 55 System autopilot (A/P) has a heading select (mode HDG) and a route intercept tracking (mode NAV) by means of VOR or RNAV equipment. A vertical speed command (mode VS) and altitude hold (mode ALT) are also provided.

The autopilot controls roll and pitch axis by signal inputs from the electrical turn coordinator and the vacuum driven directional gyro.

The different modes are selected by the pilot on the flight guidance programmer/computer.

An optional autotrim function is available.

**SYSTEM SCHEMATICS**

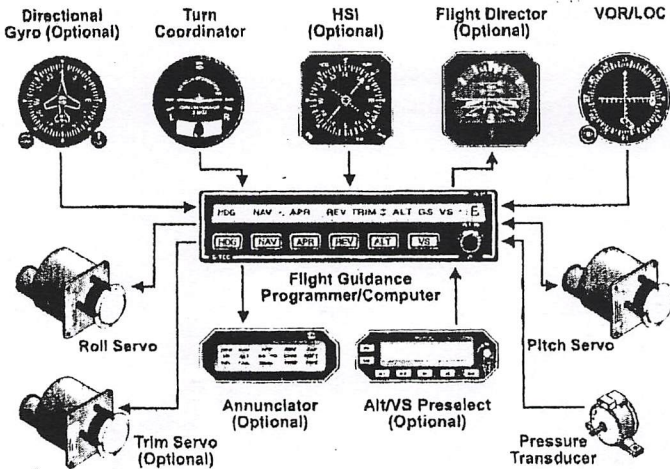

**SECTION 2 - LIMITATIONS**

The limitations of section 2 remain unchanged except:

IFR, glider and banner towing are not allowed with the autopilot in operation.

- Minimal height in descent.....500ft
- Minimal height in cruise.....1000 ft
- Minimum speed.....(75 kt) 139 km/h
- Maximum speed.....(140 kt) 260 km/h

**NOTE**

*Do not use the autopilot if following failures have been detected:*

- 1) *directional gyro, vacuum pump or vacuum circuit*
- 2) *electrical turn coordinator*

The following placards complete those of the page 2.08:

On panel  
(master switch)

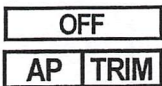

Near flight guidance  
programmer

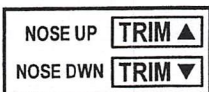

On the stick grip

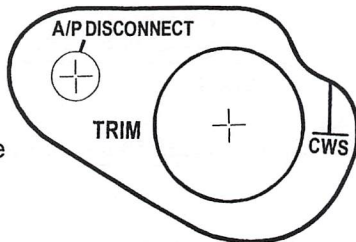

Near breakers

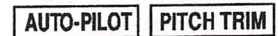

On selector switch,  
when equipped with  
optional flight director

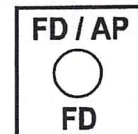

Trim and **CWS** interrupt buttons are located on the left hand stick.

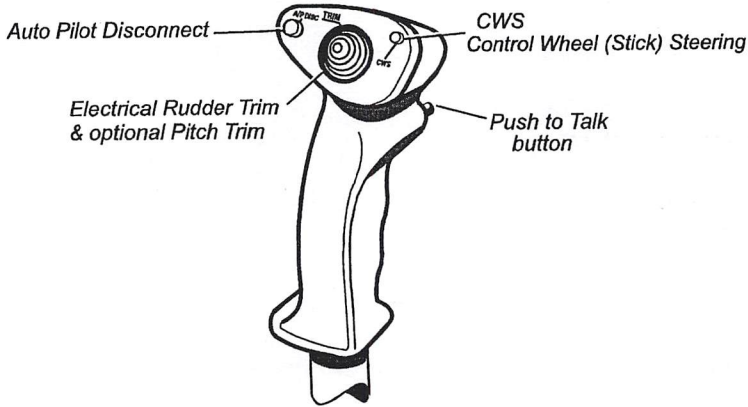

### SECTION 3 - EMERGENCY PROCEDURES

In case of A/P failure:

- 1- Override the controls (roll, pitch) as necessary and disconnect A/P by pushing the red A/P button on the stick

**NOTE**

*The A/P can be overridden without damage to the system.*

- 2- Disconnect A/P by means of the switch on the panel
- 3- Pull the breaker and don't try to switch on the A/P



In case of electrical or pneumatical failure:

Switch off the A/P with A/P master switch.

**NOTE**

*The A/P may be switched off by following means:*

- *Depress red A/P button on the stick (A/P is not working anymore but still under power)*
- *A/P master switched off (A/P not powered)*
- *Pull A/P circuit breaker (A/P not powered)*
- *If the aircraft is equipped with optional autotrim **and** ALT or VS modes are engaged, depress trim switch on stick.*

In case of electrical trim failure (if equipped):

- 1- Pull electrical trim breaker and do not try to switch on the electrical trim again
- 2- Trim manually in respect with the indication on the programmer/ computer

SECTION 4 - NORMAL PROCEDURES

4.1 – Preflight procedure

After engine start, directional gyro and turn coordinator must be powered.

Switch on A/P by means of A/P master switch. A self test will be performed. All segments of programmer/computer display will illuminate.

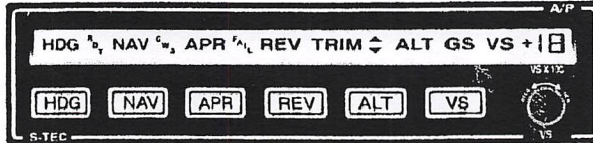

After seconds a satisfactory completion is indicated by RDY:

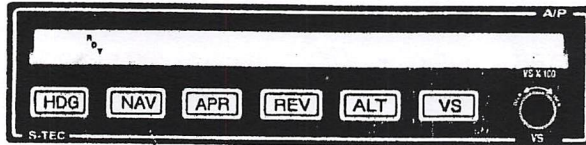

Should a fault be detected, the FAIL annunciator will remain and A/P cannot be engaged.

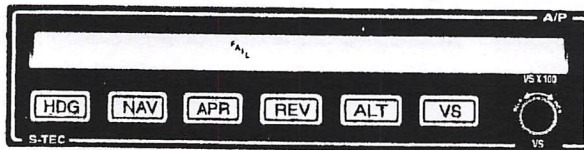

In that case, the A/P should be switched off.

**NOTE**

*If the A/P detects the turn coordinator rotor speed as low or not turning, the display will remain blank and the A/P cannot be engaged.*

At holding point, check the A/P working properly:

- 1- Vacuum: green arc
- 2- Master switch: ON
- 3- Display: RDY after autotest
- 4- Press and release CWS: CWS and VS annunciated
- 5- Overpower the A/P by moving stick in both pitch and roll axes:  
Control motions should be smooth, without looseness or free play
- 6- Press the red A/P disconnect on stick:  
RDY will flash  
An audible tone should be heard indicating the A/P disconnect
- 7- Move aircraft controls to ensure freedom and A/P disconnect

If optional autotrim is installed:

- 1- Autotrim switch: ON
- 2- Display: RDY
- 3- Press and release CWS: CWS and VS annunciated
- 4- Push stick forward:  
After 3 seconds, trim should run "nose up"  
And display indicates Trim  $\Delta$  (nose up)
- 5- Pull stick backward:  
After 3 seconds, trim should run "nose down"  
And display indicates Trim  $\nabla$  (nose down)
- 6- Move manual electrical trim switch up and down.  
Trim should operate into the commanded selection:  
RDY will flash.  
An audible tone should be heard indicating the A/P disconnect.

**NOTE**

*Retrim aircraft for take off. Be sure A/P is disengaged.*

## 4.2 - Operating procedure

Find below an abstract of the main functions and operating procedure of the S-TEC 55 system. For more details, refer to the S-TEC Pilot's Operating Handbook (p/n 8747) latest edition.

### Control Wheel Steering (CWS)

This mode engage both pitch and roll axes of the system and synchronize the A/P with the present aircraft attitude.

- 1- Depress and hold the CWS switch located on the stick.  
CWS and VS modes will annunciate and RDY will extinguish

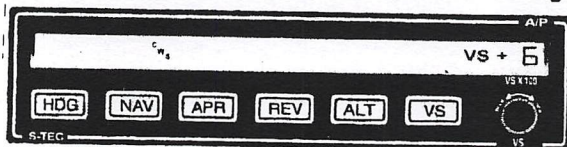

- 2- Position of the aircraft in the desired roll and pitch attitude.  
Aircraft vertical speed x 100 ft/min will be displayed in the display window above the VS selector knob
- 3- Stabilize the desired attitude for 2 or 3 seconds, release the CWS switch.  
The A/P will maintain the required attitude.

### **NOTE**

*If the bank angle is greater than a standard rate of turn when the CWS switch is released, the bank angle will be reduced to produce 90% of a standard rate turn as a maximum.*

*From the CWS mode, the pilot may select other modes such as HDG, NAV, ALT or may modify the present vertical speed using the VS knob.*

*The CWS mode can be reentered at any time by simply depressing the CWS switch. An audible tone will be heard indicating servo disengagement.*



**Heading mode (HDG)**

Heading mode (HDG) may be selected initially from CWS or RDY mode.

- 1- Set the heading bug on the directional gyro (or optional HSI)
- 2- Select the HDG switch on the programmer/computer.  
HDG annunciator will illuminate.

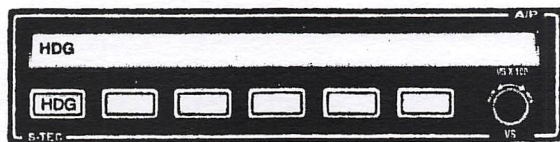

**NOTE**

*New headings can be selected simply by repositioning the heading bug.*

*In heading mode, the A/P is not coupled to any navigation aid. It may be necessary to compensate for wind drift.*

NAV intercept and tracking

To intercept and track a VOR, RNAV:

- 1- Tune the proper frequency and select the desired course
- 2- Move the heading bug in the direction of desired travel to match the selected course
- 3- Engage NAV mode.....NAV will illuminate



**NOTE**

- *If the course needle is at full scale deviation (left or right), the A/P will establish a 45° intercept angle. As the aircraft approaches the selected course, the intercept angle will be gradually reduced.*
- *During the intercept sequence the system operates at 90% standard rate turn.*
- *The system measures the difference between actual and desired course. If the aircraft is established at 50% or more than desired course the NAV message will flash. It also may flash at station passage or when the NAV indicator flags. In this case, FAIL will illuminate.*

When a course change of 10° or more is required at enroute VOR:

- 1- Select the new course
- 2- Reset the NAV mode to reinstate the capture sequence
- 3- Set the HDG bug to the new course

The pilot may select an angle of intercept less than the standard 45°:

- 1- Place heading bug on the desired heading to be used for the course intercept
- 2- Push both HDG and NAV switches simultaneously. Both HDG and NAV will be annunciated.

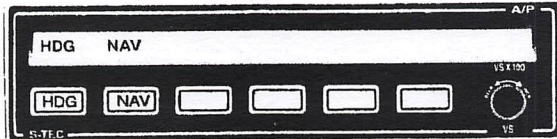

**NOTE**

*The selected heading will now be flown until the A/P computes that a turn must be made to intercept the selected course.  
- At the beginning of the turn: HDG will extinguish.*

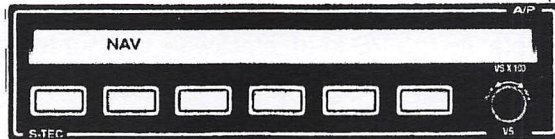

- Set the heading bug on the selected course.

**NOTE**

*Intercept angles greater than 45° usually in some course overshoot. Therefore, this type of intercept is not recommended.*

**NOTE**

*If your aircraft is HSI equipped, it is not necessary to set the heading bug on the selected course to intercept.*

**Approach mode (APR)**

The APR mode provides increased sensitivity for VOR or GPS navigation.

The pilot may select this mode if increased sensitivity is desired for enroute NAV tracking. NAV and APR will be annunciated.

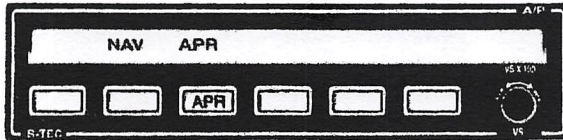

**Vertical Speed mode (VS)**

In order to engage vertical speed, the roll axis must be engaged (CWS, HDG, or NAV mode).

In VS mode, the pilot may select the desired vertical speed in 100 ft increments by rotating the VS knob clockwise or counterclockwise.

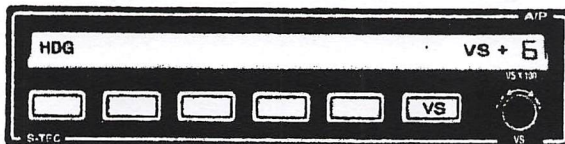

The A/P annunciates and maintains the vertical speed at the time the mode is selected. The pilot may modify the vertical speed by rotating the VS knob.



**NOTE**

*The pilot must be careful not to select a vertical speed which is in excess of the climb performance of the aircraft.  
At full throttle, flaps up, following vertical speed can be maintained:*

Weight Kg (lb)	Zp = Sea level		Zp = FL 75	
	Vi (kt) km/h	VS (ft/min)	Vi (kt) km/h	VS (ft/min)
1150 (2535)	(92) 170	984	(84) 155	510

**A positive (climb) Vertical Speed should not be selected if the indicated airspeed results in a speed lower than the A/P minimum speed of 139 km/h (75 kt).**

**This also applies to negative (descent) Vertical Speed which should not exceed the maximum A/P airspeed of 260 km/h (140 kt).**

**NOTE**

*The + (positive) symbol annunciates a climb vertical speed selection.*

*The – (negative) symbol annunciates a descent vertical speed.*

*The VS mode annunciator flashes as an indication of excessive error between actual and selected vertical speed (usually in a climb) and the pilot should adjust power or reduce the selected vertical speed.*

**Altitude mode (ALT)**

The altitude hold mode (ALT) may be engaged with any roll mode (HDG, NAV), or CWS, VS mode by pressing ALT mode switch.

**ALT mode selection**

The aircraft will maintain the pressure altitude present at the time of mode selection. ALT will annunciate.

**NOTE**

- *The pilot may adjust the selected pressure altitude by rotation of the VS knob. Each "click" will increase or decrease the altitude by 10 ft.*

*The maximum correction is  $\pm 200$  ft ( $\pm 20$  clicks).*

- *Correction in excess of  $\pm 200$  ft will require selecting the VS mod and reengaging ALT mode.*

**REMARK**

*Radioelectric interferences (VHF emission) may result in pitch oscillation when ALT mode is engaged. A temporary altitude loss of 100 ft maximum can occur.*

**Pitch trim indicator**

The programmer/computer indicates if the pilot has to trim the aircraft by annunciating following symbols:

Trim  $\Delta$  .....Trim nose up  
Trim  $\nabla$  .....Trim nose down

A placard is located near the programmer/computer to remind the symbols.

This annunciation will be steady for about 4 seconds in addition an audible tone will sound, then will flash until proper trim conditions have been met.

**NOTE**

*If TRIM is annunciated and the pilot disengages the A/P, there will be a residual out of trim force at the control stick.*

**Optional autotrim**

If the autopilot is equipped with optional autotrim, the aircraft elevator trim will be maintained automatically when the trim master switch is on and a pitch mode engaged (VS, CWS, ALT).

When the elevator trim is in motion

Trim  $\Delta$  ..... Trim nose up

Trim  $\nabla$  ..... Trim nose down

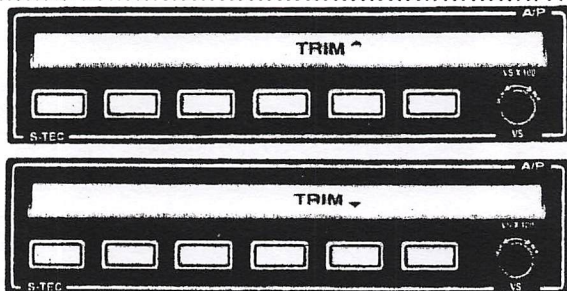

**NOTE**

- The message TRIM will flash should the trim continue to run in excess of 7 seconds.
- If the trim breaker is pulled or a failure has occurred in the auto trim, the system will revert to "Pitch trim indicator" operation (refer to preceding §)

**NOTE**

Using the trim switch on the control stick while the pitch axis of the A/P is engaged will disconnect the A/P.

The autotrim option also provides the pilot with manual electric trim when the A/P is disengaged (RDY) or if only a roll axis mode has been selected (HDG or NAV).



To use electric trim, push the trim toggle switch located on control stick. The TRIM message will flash while the trim is in motion.

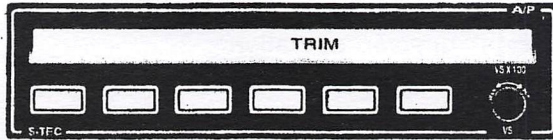

### Final descent

During final descent, the A/P has to be disconnected at the latest height of 500 ft by depressing the red A/P disconnect on the control stick.

### Optional flight director

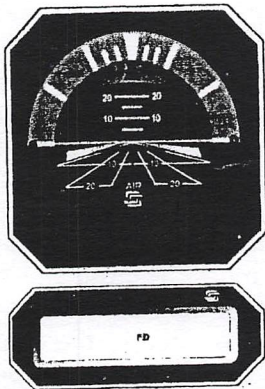

This system, which integrates both the roll axis and pitch axis, offers synchronized display of the flight profile? It is automatically activated when the autopilot is engaged. A flight director provides a visual indication of how accurately the pilot or autopilot is tracking the commands of the active mode of operation.

Activation is indicated by the FD annunciator on the remote annunciator.

A remote **Parallax Adjustment** is provided to change the height of the horizontal display to compensate for different seat heights and a remote switch allows flight director operation when the autopilot is not in use.

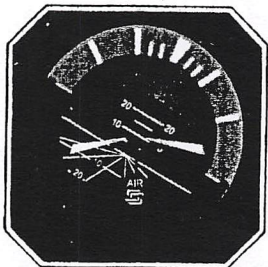
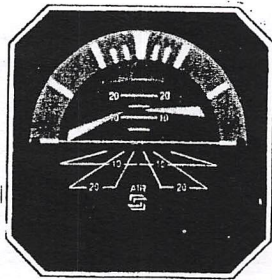

For proper flight technique, the system presentation requires the pilot to roll and pitch the aircraft toward the steering command bars until the delta-shaped reference is tucked into the steering command bars, indicating that commands have been satisfied. For example, if the display is up and left, the pilot would be required to establish a left turn, pitch-up attitude.

As bank angle and vertical speed approach the required amounts, bank angle and pitch-up attitude are shallowed. When the delta reference and the steering bars are matched the commands have been met. Thereafter, it is necessary to maneuver the aircraft to keep the display elements matched in order to accurately fly the programmed modes.

Accurate flight director operation requires alertness by the pilot and monitoring of the movement of the display. Keeping it matched is quite simple. However, control inputs must be timely for accurate flight director following of the desired command.

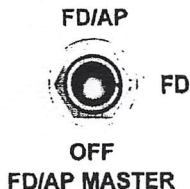

For manually controlled flight by flight director, place the **FD/AP** master switch in the "FD" position. This disables the autopilot servos, allowing the pilot to control the aircraft to the flight director commands.



To engage the autopilot without interruption, simply place the **FD/AP** master switch in the "FD/AP" position.

**NOTE**

*A pitch mode "ALT" or "VS" and a roll mode "HDG", "NAV" or "REV" must be activated before the steering command bars will come into view.*

**SECTION 5 – PERFORMANCE**

Not affected.

**SECTION 6 – WEIGHT AND BALANCE**

No change.

PAGE INTENTIONALLY LEFT BLANK



**SUPPLEMENT 7    Sensenich 76EM8S5-0-58 Propeller**

**TABLE OF CONTENTS**

Section 1	Description.....	7.46
Section 2	Limitations.....	7.46
Section 3	Emergency procedures.....	7.46
Section 4	Normal procedures.....	7.46
Section 5	Performance.....	7.47
Section 6	Weight and balance.....	7.47

**SECTION 1 - DESCRIPTION**

The Sensenich 76EM8S5-0-58 Propeller can be fitted as an option.

**SECTION 2 - LIMITATIONS**

The procedures of the Section 2 are not modified.

**SECTION 3 - EMERGENCY PROCEDURES**

The procedures of the Section 3 are not modified.

**SECTION 4 – NORMAL PROCEDURES**

The procedures of the Section 4 are not modified, except those hereunder:

Take off  
Minimal full throttle rpm .....2350tr/min

**SECTION 5 – PERFORMANCES**

**Noise limitation**

In compliance with the decree of 19.02.1987, the maximum acceptable noise level for the DR400/180 aircraft, at a certified gross weight of (2425 lb) 1100 kg, is 84.6 dB(A) (OACI chapter 10, annex 16 ).

The noise level determined under the conditions of the decree, is 75.2 dB (A).

The DR400/180 aircraft has received noise limitation certificate nr N45.

- Take off distance ..... 14 % decrease
- Climb performance at sea level ..... 10 % increase
- Best climb speed..... 86 kt (160 km/h)
- Cruise speed..... 14 % decrease

**SECTION 6 – WEIGHT AND BALANCE**

The procedures of the Section 6 are not modified.

PAGE INTENTIONALLY LEFT BLANK



## TABLE OF CONTENTS

Section 1	Description.....	7.50
Section 2	Limitations.....	7.52
Section 3	Emergency procedures.....	7.53
Section 4	Normal procedures.....	7.54
Section 5	Performance.....	7.56

## SECTION 1 - DESCRIPTION

The DR400/180 may be used for IFR operation in non-icing conditions subject to application of major modification no. 40 (latest revision). Major modification no. 40 relates to the installation of different instrument panel lighting and a different electrical system.

For IFR operation, it is mandatory for the DR400/180 IFR to have all of the equipment below installed in addition to the daytime VFR equipment, or alternatively, the equipment required by the country of registration.

### Flight and navigation

- the air speed indicator must be fitted with a device for preventing icing (pitot heater). The pitot heater must be fitted with a warning light;
- two sensitive and adjustable altimeters graduated at 1000 feet (304,80 m) per revolution and with a pressure datum subscale in hectopascals;
- a vertical speed indicator graduated in feet per minute and fitted with stops;
- a compensable magnetic compass;
- an artificial horizon;
- a second artificial horizon or a gyroscopic turn co-ordinator with a separate power supply from the first artificial horizon.  
At least one of the artificial horizons must have a power failure indicator on or near the instrument;
- a ball type bank indicator if the aircraft is fitted with two artificial horizons;
- an alternative static pressure source or equivalent device.  
The two static pressure systems must be independent, or the two static pressure sources must be independent with a means of selecting one or the other;
- a thermometer that can be read from the pilot's seat indicating the outside temperature;
- a directional gyro;
- a stop watch indicating hours, minutes and seconds;
- two VOR receivers;
- an ADT receiver;

## *FLIGHT MANUAL DR400/180*

---

- on-board equipment so the aircraft can comply with published flight paths and at least one published approach procedure for the destination airfield and alternative airfield(s);
- a system of anti-collision lights;
- a system of navigation lights;
- a landing light;
- at least one taxiing light;
- a self-contained electric flashlight for each crew member as a minimum operating requirement;
- a device for lighting the flight instruments and essential safety devices. The lighting system for reading and using the different flight instruments and essential flight safety devices must be of adjustable intensity and must be backed up by a fixed stand-by lighting system;
- audio control panel light;
- the pitot heater must be fitted with an warning light.

### **Communication**

- two microphone-earphone headsets, or two microphones and one earphone headset and a cabin loud speaker;
- two 25 kHz VHF transceivers;
- in H-type zones, an HF transceiver.

### **Supervision**

- an emergency locator transmitter operating automatically on impact (ELT);
- a Mode A and Mode C secondary radar on-board transponder with Mode S level 2 encoding altimeter or transponder.

## SECTION 2 – LIMITATIONS

The aircraft is authorised for IFR operation when it is fitted with the equipment required by the regulation in the country of registration.

This equipment must be fully operational.

The limitations in Section 2 are not affected by IFR operation except for the following placards, which must be displayed in full view of the pilot:

**THIS AIRCRAFT MUST BE USED IN THE NORMAL  
CATEGORY IN ACCORDANCE WITH THE  
APPROVED FLIGHT MANUAL.  
MANEUVERING SPEED: 215 km/h- 116 kt**

---

**APPROVED FOR IFR FLIGHT  
IN NON-ICING CONDITIONS.  
SPINS PROHIBITED - NO SMOKING**

Replaces the  
VFR flight conditions  
placard (page 2.08)

**ALTERNATE  
STATIC  
SOURCE**

**ON**

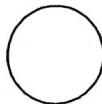

**OFF**

On the alternate  
static switch

**USE OF THE ALTERNATE STATIC  
SYSTEM PRODUCES  
THE FOLLOWING  
INSTRUMENT ERRORS**

**INDICATED SPEED + 3 kt  
INDICATED ALTITUDE + 40 ft**

Near the alternate  
static switch



### SECTION 3 - EMERGENCY PROCEDURES

The emergency procedures below supplement those of Section 3.

#### Air speed indicator failure

If the air speed indicator shows incorrect indications, check the pitot tube heater system:

- pitot heat on.....warning light (amber) off
- Warning light on indicates a pitot heating system failure

#### Lighting failure 1

- Lighting 2.....on
- Lighting 1 fuse.....checked

If the fault cannot be corrected, lighting 2 and the flashlight are used as back-up lighting.

#### Landing light failure

- Landing light circuit breaker switch.....checked

#### Battery failure

In the event of total battery failure causing alternator excitation failure, and so a total electrical failure, proceed as follows:

- battery master switch.....off
- alternator master switch.....off
- radio switch.....off
- alternator excitation.....off
- alternator excitation.....on
- alternator master switch.....on
- radio switch.....on

Check whether power is restored to the systems. Switch on only those systems required for flight safety.

### **Total electrical failure**

Check the battery and alternator circuit breaker. If the battery circuit breaker only has tripped:

- switch off the electrical equipment that is not essential to the flight
- re-arm the battery and alternator circuit breaker
- switch off all the electrical items if necessary
- use the safety flashlight
- land maintaining the attitude given by ILS slope pre-displays

## **SECTION 4 - NORMAL PROCEDURES**

The following normal procedures supplement those of Section 4.

### **Preparation**

Examine the weather forecast to avoid dangerous flying conditions (minima, icing, etc.).

Check there is sufficient fuel for the planned flight and to comply with regulations.

### **Pre-flight inspection**

Check the following equipment is operational:

Anti-collision lights.....	checked
Navigation lights.....	checked
Cabin lights.....	checked
Flight instrument lights.....	checked
Dimmer.....	checked
Battery-operated flashlight on board.....	checked

## Taxiing

Anti-collision lights.....	on
Navigation lights.....	on
Pitot heater.....	off
Gyroscopic instruments.....	checked by successive left and right turns
Artificial horizon.....	set
Directional gyro.....	correct rotation
Turn and bank indicator.....	correct deviation

## Before take-off

Pitot heater.....	on
Instrument vacuum.....	checked
VHF.....	test
VOR.....	test
Radio compass.....	test
Marker beacon lights.....	tested
Transponder.....	stand-by
Heating demisting.....	as required

## Line-up

- Directional gyro adjustment.

## Take-off

- Maintain vertical speed indicator positive at all times
- Switch of taxiing and landing lights at end of runway

## Climb and cruise

Above 8000 feet, the pilot may experience night vision problems

**Landing**

Landing light.....on

Taxiing light.....on

After engine shut-down

Lights.....off

**SECTION 5 – PERFORMANCES**

The performances in Section 5 are not affected.



1	True Airspeed indicator	22	Throttle control (dual)
2	Gyro horizon (pneumatic)	23	Mike and headset jacks
3	Altimeter, sensitive (ft - mb)	24	Fresh air vent
4	Turn coordinator, (electric) / Auto pilot STEC30	25	Battery / alternator safety switches
5	Directional gyro, pneumatic with heading bug	26	Magneto switch
6	Rate of climb indicator, ft/min	27	Mixture control
7	Vacuum gauge	28	Electric fuel pump control (safety switch)
8	Tachometer	29	Carburetor heat control
9	Parking brake control knob	30	Fuel tank selector
10	Oil pressure	31	Starter push-button
11	Oil temperature	32	Elevator trim control wheel
12	Fuel pressure	33	Elevator trim position indicator
13	Automatic pilot breaker	34	Cabin heat / windshield defrost controls
14	Fuel gauges (Left tank, Main tank, Right tank)	35	VOR / LOC / Glide indicator 1 (KI 204)
15	Magnetic compass	36	3-3/8" (80 mm) instrument cut off
16	Warning lights : Oil press. low, Fuel press. low, Fuel level low, Low Volt, Starter motor engaged, Flaps down, pitot heat (one standbylight)	37	3-3/8" (80 mm) instrument cut off
17	Lights test & day / night dimmer switch	38	EGT
18	Instrument panel lighting (from LH to RH): light 1 (under glareshield), light 2 (overhead flood lights), radio (avionics integrated lighting)	39	OAT
19	Safety switches (from LH to RH): Landing light, Taxi light, Strobe light, Navigation lights, Pitot heat	40	ELT remote control
20	Fuses (radio)	41	Voltmeter
21	Breakers	42	3-3/8" (80 mm) instrument cut off
		43	Flight hours recorder
		44	Avionics master switch
		45	Ancillary 12V
		46	P.A. Switch
		47	P.A. disconnect
		48	Altitude engage/disengage

PAGE INTENTIONALLY LEFT BLANK



## AIRCRAFT FLIGHT MANUAL SUPPLEMENT

### AUTOMATIC PILOT S-TEC SYSTEM 20 & 30

This supplement includes the information to be provided to the pilot, as required by the certification basis.

**This supplement supersedes any existing supplement in section 7 concerning the automatic pilot S-TEC SYSTEM 20 & 30.**

Revision	Date	Description	DGAC approval
	Dec. 11 <sup>th</sup> , 2002	Original issue	17 MAR 2003 

## 1. GENERAL

### 1.1. Applicability

Aircraft type	Manufacturer change
DR400/500	Nr 128
DR400/180	Nr 128



**AIRCRAFT FLIGHT MANUAL SUPPLEMENT**  
**AUTOMATIC PILOT S-TEC SYSTEM 20 & 30**

**1.2. Description**

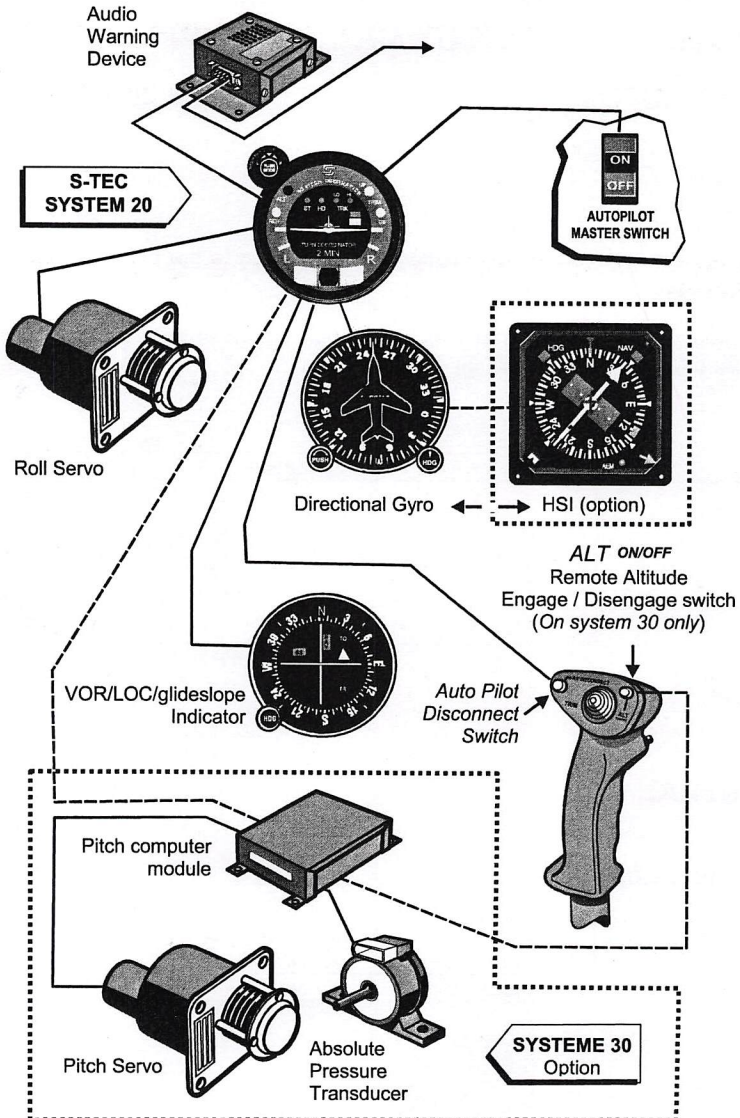





The S-TEC system 30 is a two axis automatic pilot (AP) that uses the tilted gyroscope of the turn coordinator as sensor of roll and rate of turn. For pitch control, it bases itself on data of the built-in accelerometer of the pitch computer and a pressure transducer. The turn coordinator incorporates an anomaly detector (electric power supply, speed of rotation of the gyroscope).

Heading track mode can be installed in option, as well as the elevator electric trim.

The S-TEC system 20 is similar to system 30, apart from the pitch control system.

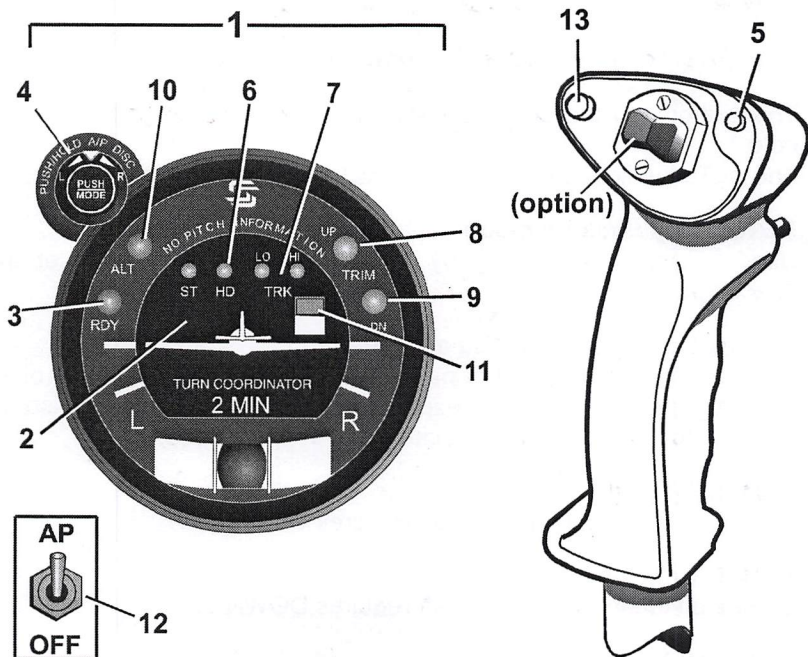

**1. Turn coordinator, mode and display selector**

**2. Annunciator panel**



**3. RDY green light**

Comes on when AP can be engaged. If the AP disconnects, the light flashes with a five-second audible beeping tone.

**4. AP switch-off and mode select knob**

With each push on this knob, any one of the four modes is engaged sequentially, from left to right, starting with the ST mode (stabilizer) and finishing with the HI TRK mode (tracking of a route with a high gain).

AP is disconnected by pressing and holding the push mode select knob for more than 2 seconds.

In ST mode, when turned left or right, it sends a proportional turn command to the AP up to a standard turn rate.

**5. Engage/disengage button for Altitude hold**

This button (on the stick) is used to engage/disengage the altitude hold.

The ALT blue light comes on when ALT mode is engaged.

**6. HD heading tracking mode**

Used to select a heading by means of the heading bug of the directional gyro.

**7. TRK(Not connected on this airplane)**

Tracking of a VOR or GPS navigation route, in Lo gain (low) or Hi gain (high) according to the expected response. Use Lo in cruise, Hi in cruise for a more precise tracking and in GPS mode.

**8. TRIM UP (\*) light**

Comes on to indicate the aircraft requires UP trim.

**9. TRIM DN (\*) light**

Comes on to indicate the aircraft requires DOWN trim.

**10. ALT (\*) blue light**

Comes on when Altitude mode is engaged.

(\*) System 30 only



**11. Red flag window**

Indicates that voltage is not adequate.

**12. AP ON/OFF switch, located on the instrument panel.**

**13. AP ON/OFF switch, located on the stick.**

**2. LIMITATIONS**

Limitations of the section 2 are not modified by the installation of auto pilot **S-TEC System 20 or 30**.

The following limitations, pertinent to the automatic pilot, must be added:

This automatic pilot is not allowed in IFR, nor in tow of gliders and streamers.

Do not operate AP during approach.

Minimum height for use ..... 1 000 ft

Minimum speed for use ..... (75 kt) 139 km/h

Maximum speed for use ..... (140 kt) 260 km/h

**IMPORTANT**

Do not use the automatic pilot in case of failure of:

- 1) of the directional gyroscope, of the vacuum pump or the air feeding circuit,
- 2) of the electric turn coordinator



Following placards must be added to previous ones.

*AP master switch  
on instruments  
panel*

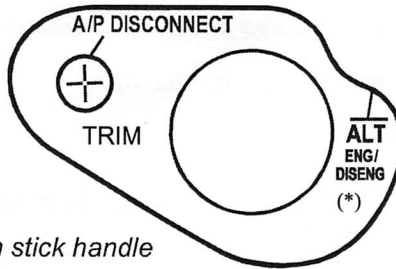

*Cct Breaker*

**AUTOPILOT**

**ALT  
ENG/  
DISENG  
(\*)**

*On stick handle*

(\*) System 30 only

### 3. EMERGENCY PROCEDURES

If the AP malfunctions or if the response is not consistent with the expected control order, take over the controls manually rather than looking for the cause of the problem. Then disconnect the AP. Do not attempt to restart it until the problem has been identified and corrected.

The AP may be disconnected in several ways:

- by pressing on the red "AP disc " switch on the stick,
- or by pressing the mode selector for 2 seconds,
- or by putting the AP switch on the instrument panel to the OFF position,
- or by disabling the AP circuit breaker.

#### NOTA

***In case of malfunction of the electric trim (if installed),  
disable the circuit breaker of the electric trim.***





## 4. NORMAL PROCEDURES

### Check before flight

1. There must be adequate aircraft DC voltage (12 Vdc).
2. Engage the AP using the AP switch on the instrument panel.
3. All lights must come on.
4. Watch the trim indicator lights come on in the following sequence (duration 9 seconds) (\*):
  - a. Initially, the UP and DN trim lights are on.
  - b. The UP light goes off and stays off.
  - c. The DN light goes off and stays off.
  - d. All other lights go off except for the RDY light.

The AP can then be engaged and disengaged repeatedly, unless the AP switch on the instrument panel is switched off. In this case, the sequence must be repeated.

**NOTE (\*)**

*ALT mode cannot be engaged until after 15 seconds.*

5. Press the mode selector. The ST light comes on.  
Turn the knob to the left or the right, check that the stick moves respectively in the right direction. Put the knob back in the center position.
6. Adjust the directional gyro and center the heading bug (if installed).  
Press the mode selector to engage HDG mode: the HDG light must come on. Move the heading bug to the left or right. The stick must respectively move in the right direction.
7. Override the AP manually. There must not be any play, or jerks or noise or excessive stiffness.

(\*) System 30 only



8. Check navigation:  
Initiate a VOR and engage Lo TRK mode. Move the VOR OBS needle towards the left or right. Check that the stick respectively moves in the right direction. Change to Hi TRK mode. Perform the same test. The stick movement must be slightly faster.
9. (\*) Put the stick back in the center. Engage ALT mode. Override the AP by pushing and pulling it. There must not be any play, or jerks or noise or excessive stiffness.
10. (\*) Pull on the stick for 2 to 3 seconds: the TRIM DN light must come on. Push the stick: the TRIM UP light must come on. Put the stick in the middle: the two lights must go off.
11. (\*) Put the stick back in the center. Push the mode selector for 2 seconds. Check that the roll and pitch servos disengage and that the stick is free. Re-engage the AP and check it disconnects with the AP disconnect switch on the stick.

### **In flight**

1. Check that the RDY light is on.
2. Trim the aircraft for level flight conditions, with the ball in the center.
3. Center the turn button. Press the turn button to obtain the ST mode.
4. Make the required turn or keep the wings horizontal.
5. If the heading bug is installed, put it to the desired heading and press the button to obtain HDG mode.
6. (\*) At the required altitude, press the ALT mode button on the stick. Trim the aircraft according to the indications of the light. If you want to climb or descend, disengage the altitude hold with the button on the stick.  
Note: Maneuvering the flaps or fast power variations can cause inaccuracy in altitude hold.

(\*) System 30 only



### **VOR tracking**

1. Select the VOR frequency and the radial.
2. Turn to track the radial within approximately a needle width of the VOR OBS, or at plus or minus 10° from the required heading.
3. Engage Lo TRK mode.
4. Engage Hi TRK mode if necessary.

### **GPS tracking (for aircraft equipped with a NAV/GPS source selector)**

1. Start tracking with a reliable GPS signal and with the deviation needle centered with the aircraft on the heading necessary to reach the chosen point.
2. Select Hi TRK mode.

## **5. PERFORMANCE**

No change.

## **6. WEIGHT AND BALANCE**

No change.







# AIRCRAFT FLIGHT MANUAL SUPPLEMENT

## BENDIX/KING KMD 150

### COLOR MULTIFUNCTION DISPLAY / GPS

#### FOR DAY VFR

This AFMS includes the material required to be furnished to the pilot and additional information provided by the manufacturer. The information contained herein supplements or supersedes the DGAC approved AFM & POH. This AFMS is the English translation of the French approved AFMS, which remains the reference in any case.

This supplement supersedes any existing supplement concerning the BENDIX/KING COLOR MULTIFUNCTION DISPLAY / GPS KMD 150 for a day VFR.

### LIST OF EFFECTIVE PAGES

Pages	Date
1 to 2	October 2004

DGAC Approval:

Lettre 2004/4463 – SFACT/N du 09 décembre 2004.

## 1. GENERAL

### 1.1. Applicability

Aircraft type	Manufacturer change
DR400/120	No. 040901
DR400/140B	No. 040901
DR400/160	No. 040901
DR400/180	No. 040901
DR400/180R	No. 040901
DR400/200R	No. 040901



## **1.2. Description**

The Bendix/King KMD 150 is a color multifunction display with a built-in GPS receiver.

Note : Bendix/King makes «data base» cards available to users.

The installed "avionics master" switch provides the radio bus with electrical power supply to the breakers of the KMD 150.

## **2. LIMITATIONS**

The color multifunction display/GPS KMD 150 is not approved for use with an external GPS.

The BENDIX/KING KMD 150 owner's manual (P/N 190-00067-80), must be on board.

Information provided by the KMD 150 are to be used for advisory only and must not be used for navigation.

A placard «KMD 150 for advisory only» must be displayed in the aircraft.

**Coupling of the GPS to a flight director or to an automatic pilot system is forbidden.**

## **3. EMERGENCY PROCEDURES**

No change.

## **4. NORMAL PROCEDURES**

The BENDIX/KING KMD 150 owner's manual (P/N 190-00067-80), must be on board.

## **5. PERFORMANCE**

No change.

## **6. WEIGHT AND BALANCE**

No change.

**SUPPLEMENT**

**INSTRUMENT PANEL**

**LIST OF CURRENT PAGES**

<b>Pages</b>	<b>Date</b>
1 to 3	March 2005

DGAC (French authority) approval:

**CHRONOLOGICAL ACCOUNT OF ISSUES**

<b>Issue</b>	<b>Subject</b>
1	Original instrument panel –July 2004.
2	Auto-pilot STEC30 installed

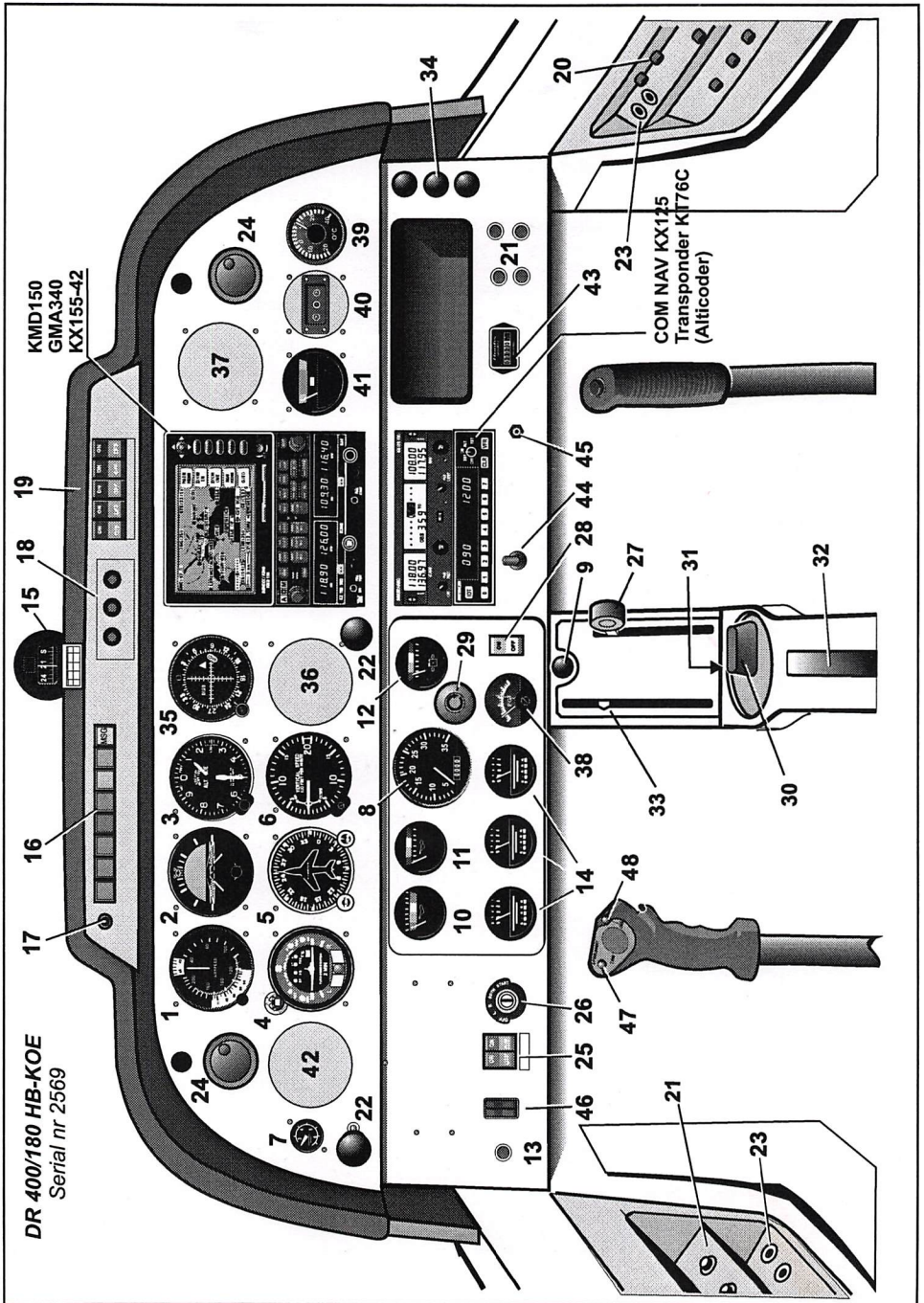

**AIRCRAFT FLIGHT MANUAL SUPPLEMENT****ELEVATOR ELECTRIC TRIM**

This supplement includes the information to be provided to the pilot, as required by the certification basis.

**This supplement supersedes any existing supplement in section 7 concerning the elevator electric trim.**

Revision	Date	Description	DGAC approval
	Dec. 11 <sup>th</sup> , 2002	Original issue	17 MAR 2003 

**1. GENERAL****1.1. Applicability**

Aircraft type	Manufacturer change
DR400/180	n°132
DR400/180R	n°132
DR400/200R	n°132
DR400/500	n°132

**1.2. Description**

An elevator electric trim tab control can be installed in option. It comprises a servo-actuator connected to the trim control system, an ON/OFF switch located on the instruments panel, a trim UP/DOWN control button located on the stick handle and a circuit breaker.





## 2. LIMITATIONS

No change.

## 3. EMERGENCY PROCEDURES

If the elevator electric trim malfunctions:

1. Oppose and correct action by means of elevator control if necessary.
2. Set the elevator trim switch to OFF and disable the elevator trim breaker.
3. Do not attempt to switch it back ON.
4. Manually operate the tab to trim the aircraft.

## 4. NORMAL PROCEDURES

### 4.1. Before take-off.

1. Elevator trim breaker ..... IN
2. Elevator trim switch ..... ON
3. Elevator electric trim control ..... DOWN trim / UP trim  
Make sure the elevator trim control wheel and the trim indicator move in the proper direction.
4. Trim back to take-off position.
5. Stop using the elevator electric trim during take-off and initial climb.

### 4.2. Approach

Trim the aircraft for the approach speed.

Stop using elevator electric trim during final approach and landing flare.

## 5. PERFORMANCE

No change.

## 6. WEIGHT AND BALANCE

Refer to latest weight and balance record form.



## **AIRCRAFT FLIGHT MANUAL SUPPLEMENT**

**No. 5826-011**

### **for PowerFlarm Collision Warning Device**

A/C Make : **Robin**  
A/C Model: **DR 400 / 180**  
A/C S/N : **2569**  
Registration: **HB-KOE**

This Supplement must be attached to the basic Airplane Flight Manual. It describes the operating procedures for a fix installed Power FLARM Collision Warning System and its interfaces in accordance with the FLARM/FLOICE Installation FOCA Policy 1.6 (42-00.02) or later versions.

The information contained herein supplements or supersedes the basic Airplane Flight Manual only in those areas listed herein. For limitations, procedures, and performance information not contained in this document, consult the basic Airplane Flight Manual.

**This Flight Manual Supplement Revision is EASA approved under:  
EASA CS STAN CS-SC051a.**



### Log of Revisions

Rev.-Nr.	Pages	Date	Remarks/Change	
Original Issue	1 - 9	17.06.2016	Complete Supplement	



## Table of Contents

<b>SECTION .....</b>	<b>PAGE</b>
1 GENERAL .....	4
2 LIMITATIONS .....	4
3 EMERGENCY PROCEDURES .....	5
4 NORMAL PROCEDURES .....	6
5 PERFORMANCE .....	8
6 WEIGHT AND BALANCE .....	8
7 SYSTEM DESCRIPTIONS .....	8



## SECTION 1 GENERAL

The general aviation has been confronted since years to dramatic mid air collision accidents. With the extreme fine shape and relatively high cruise speed of modern gliders, the human vision has reached its limit of detection. Another aspect is the airspace restrictions to VFR that creates an augmentation of traffic density in certain areas and the associated airspace complexity that request more pilot attention on the navigation material. These have a direct impact on the probability of collision also affecting powered aircraft or rotorcraft operations.

These equipments in the general aviation are not required by technical specifications or by operation regulations, but are recognized by the regulators as an important step toward improved aviation safety. Therefore they are not considered as essential for flight and may be used for "situational awareness only" on basis of non interference to certified equipment required for safe flight/landing and no hazard to the persons on board.

Correct antenna installation has a great effect on the transmission/receiving range. The pilot shall care that no masking of the antenna occurs especially when the antennas (GPS, ADS-B and FLARM A/B) are located in the cockpit.

PowerFLARM will only give warnings of other aircraft that are likewise equipped with a compatible unit and from aircraft equipped with ADS-B-OUT (1090ES), Mode-C and Mode-S transponders (if interrogated by ground radar or TCAS). PowerFLARM is not detected by ACAS/ TCAS/TPAS or Air Traffic Control. Likewise PowerFLARM does not communicate with FIS-B or TIS-B systems.

The software version must be regularly updated as per the instructions given in the installation manual. If a version mismatch exists, error information is displayed during the equipment Power-ON and the system will not become operational.

An on/off switch on the PowerFLARM provides ready disconnection of the PowerFLARM system from the electrical bus in case of fume, fire, interferences or when flying over territories where the SRD frequency is not available for air-air communication.

## SECTION 2 OPERATING LIMITATIONS

**2.1 This POWERFLARM installation is compliant for "situation awareness only".**

The following placard must be installed on the instrumental panel, at the proximity of the display'

For Situation Awareness only





**2.2 Maneuvering must not be based solely on the use of the information presented on the PowerFLARM displays or aural annunciations.**

PowerFLARM does not give any guidance on avoiding action. The azimuth and height accuracy of the computed traffic cannot always provide reliable warnings and only the most threatening traffic is announced. Therefore it is the pilot responsibility to evaluate by any means the real traffic position and altitude, the obstacle shape, the terrain and the meteorological situation prior executing any evasion maneuver.

**Under no circumstances should a pilot or crewmember adopt different tactics or deviate from the normal principles of safe airmanship.**

**2.3 It is the pilot's responsibility to verify prior entering any states territory that the SRD frequency is permitted for use in air-air communication.**

When such an acceptance does not explicitly or implicitly exist, the equipment shall be turned OFF. This verification is part of the flight planning.

**2.4 The pilot shall not intentionally generate uncoordinated warnings that might frighten other aircraft's pilot.**

Any intentional maneuver of this kind has to be carefully coordinated and agreed in advance. Unexpected reactions might be especially hazardous when lateral, vertical or time separations are small.

### **SECTION 3 EMERGENCY PROCEDURES**

In case of Fire, Smoke, electrical burning smells or electromagnetic Interferences follow the Emergency procedure of the basic AFM.

The dedicated PowerFLARM switch will help to rapidly determine if the PowerFLARM installation is faulty or not, allowing to resume essential equipments as per the Emergency procedure of the basic Aircraft Flight Manual. The PowerFLARM is powered by the aircraft electrical bus. In case of malfunction turn the PowerFLARM System off by selecting the FLARM Switch to the Off Position.



## SECTION 4 NORMAL PROCEDURES

### 4.1 General

It is recommended to carry the PowerFLARM Operating Manual, current revision on board the aircraft. To make good use of the information contained in this manual the pilot should know the hardware version, the software version, the serial number and the obstacle database name currently installed in the PowerFLARM.

### 4.2 Self-test

To switch on FLARM, the aircraft electrical power shall be available on the corresponding bus and the dedicated FLARM switch must be turned ON. After switching on, the system performs a self-test routine, lights up all LEDs and displays either error codes or version information. The Aboba display manual describes how errors and version numbers are shown. If an error is shown, the system is not ready for operation.

When FLARM shifts to normal operation, it waits until it has acquired an adequate GPS position fix. When switching on the device after a long period or in a new location, this procedure can take several minutes. Without a proper GPS position fix, the system is not ready for operation.

Before departure, the pilot must ensure that FLARM has acquired a GPS fix and that no errors are shown (refer to the display manual).

### 4.3 Traffic Information Presentation

FLARM can show and warn about other aircraft, obstacles, and alert zones. When there is no threat, FLARM can show information about surrounding aircraft. The types of aircraft that are shown (FLARM/ADS-B/Mode-C/S, range limits, etc.) are defined in the settings during installation. How the information is shown is described in the Aboba display manual.

When FLARM calculates a risk for an imminent collision, it will give visual and aural warnings. There are three levels of warnings, depending on time to impact. The different warnings start at approximately 185, 12s, and 8s respectively. The display will show the relative bearing and vertical angle to the intruder (Mode-C/S traffic will only be shown as approximate range and vertical angle). When receiving a warning, immediately identify the intruder visually and take corrective action, if required. Never take corrective action based solely on collision warnings or displayed traffic.

If there are several threats, FLARM will only warn about the calculated most danger threat.

Depending on the phase of the flight, FLARM uses different movement models, forecasting methods and warning calculations to provide the pilot with the best possible support without causing a distraction. For example, when a glider is circling, the system sensitivity is reduced. These models and processes have been optimized, but are nevertheless a compromise and may be wrong.

Obstacle collision warnings are always given without bearing, when there is an obstacle in the calculated future flight path. Warnings are only given about obstacles that are in the current database. The database should be updated with the AIRAC cycle, or at least once per year.



#### **4.4 Line of sight**

Compatible FLARM/FLOICE/PowerFLARM units and Transponders must be within range in order to provide a warning. The range is very much determined by the type, installation and position of the radio antennas, plus the relative positions of the two aircraft. Under optimal conditions, the system can give a range of well over 10 km. Normally, range should be minimum 3-10 km. The radio signals can only be received by line of sight. There is e.g. no FLARM communication between two aircraft on opposite sides of the same mountain. If there is only one FLARM antenna on top of the aircraft, the range directly below the aircraft will be zero or very limited.

#### **4.5 GPS signal quality**

PowerFLARM has to know its current position in order to operate. For this reason, PowerFLARM will only operate in the presence of good quality three-dimensional GPS reception. GPS reception is greatly influenced by the installation and position of the antenna, and aircraft attitude. This is particularly true during turns, when flying close to mountain slopes and in areas known for poor reception. If the installation is poor the GPS signal quality may be reduced. In particular, there can be rapid degradation of height calculations. PowerFLARM resumes operation as soon as the GPS reception quality is adequate.

#### **4.6 Predicted flight path and accuracy**

When close up, when two aircraft are at the same or similar height, or GPS reception is poor, the vertical bearing indication is imprecise and fluctuates. PowerFLARM calculates the predicted flight path of the aircraft to which it is fitted for less than the next 20 seconds. This prediction is based on immediate past data, current position- and movement data, plus a movement prediction model that is optimized for the respective user. This forecast is associated with a number of uncertainties that increase with an extension of the forecast time. There is no guarantee that an aircraft will actually follow the predicted flight path. For this reason, the warning issued will not be accurate in all cases.

#### **4.7 Effect of wind**

Movements calculated by the GPS relate to a fixed system of terrestrial coordinates. In strong wind there may be a substantial difference between aircraft heading and track, leading to a distortion of the threat bearing. If the wind speed is one third of True Airspeed (TAS) and the yaw free aircraft heading is 90° out of wind, then the threat indication displayed has an error of about 18°. If the wind is very strong, the track can deviate up to 180° from heading. Under such circumstances and when circling, the warnings given are unusable.



## 7.2 Radio transmission

The PowerFLARM system uses a data communication frequency in the SRD860 band. This band is ruled for European applications in the documents ERC/REC 70-03 annex 1 (f) and ERC/DEC/(01)04. The band is free for any ground-ground applications and gets no official protection against external interferences. POWERFLARM is not considered as aeronautical mobile radio. There are national differences in frequency allocation and operating conditions between countries. To be used for air-air application some countries require an authorization to be granted by each national communication authority. In Switzerland, BAKOM has granted this authorization for the FLARM/FLOICE/PowerFLARM application on the 23 March 2004. On the 29 May 2005 FOCA confirmed to BAKOM, that no Radio License will be required for FLARM/FLOICE/PowerFLARM. The aircraft commander is solely responsible for ensuring that their use of PowerFLARM conforms to local regulations.

The radio transmission protocol employed places no limit on the number of units that may be operated within a given range. However, an increasing number of units within range is associated with a reduction in the probability that a single coded signal will be received ('graceful degradation'). The probability is small that subsequent signals will not be received from the same transmitter.

## 7.3 Electrical installation

This FLARM installation is electrically protected with a inline fuse, which is provided with this installation to readily disconnect the PowerFLARM installation when required by Emergency or operational needs. The pilot must be confident with his electrical bus topology and the FLARM installation.

## 7.4 Personalized PowerFLARM System overview

Below a System overview installed in this aircraft. Detailed wiring interconnection No 5826-FLARM can be found in the aircraft maintenance records.

